



The Factors Attributed to Students’ Low Performance in Secondary Leaving Examination: The Case of Secondary Schools in Benadir Region of Somalia

Mohamed Ali Osman¹

Abukar Mukhtar Omar²

Journal for Educators, Teachers and Trainers, Vol. 14 (2)

<https://jett.labosfor.com/>

Date of reception: 22 Jan 2023

Date of revision: 20 Mar 2023

Date of acceptance: 21 Mar 2023

Mohamed Ali Osman, Abukar Mukhtar Omar (2023). The Factors Attributed to Students’ Low Performance in Secondary Leaving Examination: The Case of Secondary Schools in Benadir Region of Somalia. *Journal for Educators, Teachers and Trainers*, Vol. 14(2). 326-337.

¹Lecturer at the Faculty of Education, SIMAD University, Mogadishu Somalia

²Senior Lecturer at the Faculty of Education, SIMAD University, Mogadishu Somalia



The Factors Attributed to Students' Low Performance in Secondary Leaving Examination: The Case of Secondary Schools in Benadir Region of Somalia

Mohamed Ali Osman¹, Abukar Mukhtar Omar²

¹Lecturer at the Faculty of Education, SIMAD University, Mogadishu Somalia

²Senior Lecturer at the Faculty of Education, SIMAD University, Mogadishu Somalia

Corresponding Authors

Email: mali@simad.edu.so¹, abukar@simad.edu.so²

ABSTRACT

This research aims to identify the factors attributed to students' low performance in secondary school leaving examinations in the Benadir region of Somalia. The study evaluated the tendency of students' low performance in the examinations conducted from 2020 to 2022. Over the three years, academic performance has been below average, with a mean score rarely going above C- (below average). The study used a descriptive survey design analysis with basic random sampling techniques. The sample comprised 235 secondary school teachers, principals, and parents drawn from public and private secondary schools inside the Benadir region of Somalia. Data for the study was collected using a questionnaire, whereas Smart PLS 4.0 and SPSS 26.0 were used to test the hypothesis and analyse the respondents' profiles, respectively. Structural equation modelling (SEM) results were assessed to examine the causal associations between the independent and dependent variables through the mediator. According to the findings of structural equation modelling, the independent variables parent participation, school principals, and teacher qualification affect the incompetence of teacher's school principals and parents as a mediating factor led to students' low performance in secondary school leaving examination. The results also supported the hypothesis that the teachers, principals, and parents' incompetence used in this study as mediating factors may have mediated the association between representatives' schools and students' dismal academic achievement. The stakeholders were encouraged to create an environment enabling students to perform well in secondary school, leaving examinations by meeting the expectations of examining bodies.

Keywords: Students, Principals, Teachers, parents, Examination, Performance.

INTRODUCTION

Poor educational outcomes have recently emerged as a significant global issue that requires immediate consideration (Isaac et al., 2022). This issue exists in Somalia's schooling system, where most students perform below the required standard or fail. Although concern regarding poor student performance is not new, it has recently gained public attention, creating serious discomfort for the concerned educational stakeholders in society. Since education is a tool for social transformation and development, it cannot be ignored. This calls for a clear understanding of what is attributed to the student's poor performance in secondary school leaving examination.

Standardised test achievement has been an essential element of our educational system because it provides students with a chance for further academic achievement and a unique advantage in obtaining higher-paying careers. High-quality school management, regular parent involvement, and professional teachers are the most crucial elements in a school setting. They are tasked with managing the day-to-day affairs of the students—a continuous improvement collaboration allows students to receive high-quality education (Papakitsos, 2022). However, the problem of students' low performance in secondary leaving examinations in the Benadir region has been alarming and considered a concern by all stakeholders. This current problem has become more contentious among Banadir residents and all other regions in Somalia. The annual release of (SSCE) the results of National form four Examinations validate the problem of poor secondary school graduates achieving C- and C maximum passes.

Moreover, failure National Examination results in the last three years **were** about 31%, 16.83% and 4.6 % in 2020, 2021 and 2022, respectively (MOECHE). The causes of poor performance must be referred to teachers, Parents and school administration, as they are crucial to students' development. Consequently, the high failure rate has resulted in few students continuing to colleges and universities. Those who perform poorly cannot

adequately contribute to human resources because they lack the requisite abilities. According to Aremu et al. (2006), school failure annoys pupils and parents; the workforce shortage in all economic sectors has major negative effects on society. Finally, to discover a long-term solution, this study intends to identify the factors contributing to the senior secondary students' persistently poor academic performance in the Benadir region in the capital city of Somalia, Mogadishu.

The researchers formulated three hypothesises for the study:

H1: Parents' involvement in school activities determines the students' performance in the Secondary school leaving examination.

H2: School management determines the students' performance in Secondary school-leaving examination.

H3: Teacher qualification determines students' performance in Secondary school-leaving examination.

H4: Incompetency of teachers, principals, and parents will directly impact the students' performance in Secondary school leaving examination.

Conceptual Framework

Factors Responsible for low performance in Secondary leaving Examinations in Case Study of Benadir Region Somalia.

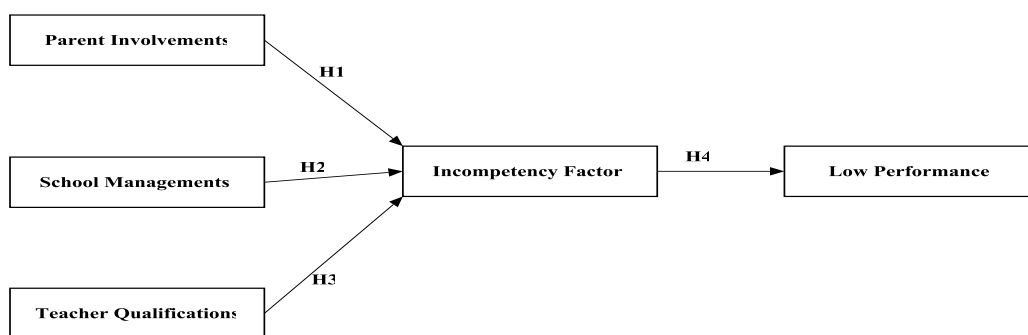

Parents' Involvements in Student Education

Parental involvement in this study includes parental attention, support for their child's education, and ability to participate at home, assisting them in completing their studies, offering advice and help, and sharing information with teachers for their student's research and interference in school-related activities. Parental support participation and excellent parental monitoring are associated with successful academic outcomes (Nazir et al., 2022). Parents involved in their children's academic achievement were more likely to incorporate hopes and ambitions in their children. Accomplishment will not happen if parents do not contribute to their children's learning and development (Wilkesmann, 2021). Schools and teachers complain that parents are not involved enough in their children's education (Anastasiou & Papagianni, 2020). Many parents have lost faith in the educational system due to negative academic perceptions (Neuenschwander, 2020). Parents who think their role is only to get their children to school, where responsibility for their education is assumed, will be unwilling to participate actively in either school-based or home-based parental involvement (Islam et al.2021). Children whose parents do not attend Parent-Teacher Association meetings, discuss their students' strengths and weaknesses with teachers and supervise homework are at a higher risk of dropping out of school (Paul et al., 2021). The reality that disadvantaged families have limited resources and lower capacity for self also contributes to their lower participation (Jabar et al., 2021). For students to succeed personally and academically, parents and teachers must maintain and improve their connections and teamwork (Lumadede et al., 2020).

School management and students' academic performance

The principal of a school is one of the instructional components with the most influences on educational quality (Widiasmara & Andriani, 2020). Noor and Nawab (2022) maintain that administrators can only become effective instructional leaders when they include teachers in more culturally relevant teaching strategies and practices that improve student outcomes. Most education scholars concur that principals are responsible for setting the tone of the school by ensuring effective school management and good instructional leadership. Most principals, however, are not fully prepared for the leadership function in the Somalia environment because they "are not professionally trained and competent for school management" Mathibe, 2007:523 cited by (Tuan et al., 2022);(W. Wamalwa et al., 2019). There is no mandatory professional training for those who want to become principals (Klein & Schwanenberg, 2022). However, if the principal fails to provide clear guidelines and clear direction, the achievement of the concerned students may suffer. The researchers discovered that these reasons for poor performance could revolve around ineffective management. Hassan et al. (2020) state that a school's leadership is crucial in determining the institution's environment.

Nonetheless, most of those school principals in Somalia's capital have failed in their management. Indeed, there has been a low numeracy and literacy rate, poor academic performance, and insufficiency of highly competent and expert teachers and schools at the advanced level of School-Based Administration. Given the issues and concerns and the lack of a shared understanding of school performance, it was deemed necessary to determine whether school administrators' leadership and central behavioural competencies can significantly influence school performance. The primary causes of a school's poor performance are illiteracy and poor leadership, a lack of academic staff responsibility, and students' loss of motivation (Parveen et al., 2021). Secondary school administrators, in general, are almost always to blame for poor administrative and academic performance. Makau et al. (2016) argue that an educated and well-trained head teacher is more successful and can improve school productivity of students' academic accomplishments. The problems of low test scores for schools and pupils have frequently been attributed to the principal's ineffective instructional leadership (Owan & Agunwa, 2019).

Teacher qualification and academic performance

The world of academic achievement cannot be disconnected from a teacher because the instructor is one of the elements determining how the education policy is performed (Purnomo et al., 2020). How essential teachers' roles are in the educational world is also necessary for providing teachers with teaching quality (A. Muhammad et al., 2020). If teachers are not highly qualified and experienced and given a Policies department, they cannot focus on their responsibilities. According to Casian et al. (2021), having qualified teachers is one of the considerations that can improve students' achievement. Teachers' qualifications significantly impact the characterization of school success (Lumadede et al., 2020). The Ministry of National Education implements the most incompetent teachers' curricula through the Somalia School Board. Low teacher engagement and enthusiasm significantly contribute to poor academic achievement (W. Wamalwa et al., 2019). Over time, the low performance of pupils in the Somalia National Examinations Board has been a direct result of the poor performance. According to Lumadede et al. (2020); Oludipe and Oludipe (2021), a constant lack of qualified teachers contributed to pupils' poor performance in SMT topics. The quality of the education showed that the students' results are not getting better due to a lack of qualified teachers in secondary schools (Haile, 2021). The community criticized most school systems for poor academic achievement, attributed to the hiring of many incompetent teachers in these schools.

However, teachers with minimal academic qualifications risk having a restricted teaching capacity, resulting in pupils' subpar academic performance. (Casian et al., 2021). According to Ogunode (2022), Low performance in public examinations has been attributed to ongoing strikes, problematic teaching methods, instructors' failure to cover the curriculum, and teachers' lack of creative problem-solving skills. The primary causes of this problem are teachers with insufficient qualifications. According to Linda (2022), of the multiple studies on student outcomes, there is a lack of understanding about why most students conduct proper in-class exercises and tests but do not repeat such achievements in their standardized tests. Other difficulties include the lack of comprehension of the subject's teaching methodologies, which causes the teachers to fail to express the subject's content well (Co et al., 2021). Compared to those with specialist knowledge in the courses taught, non-specialization teachers have a significantly weaker power to control the class throughout the teaching and to learn discussions (Razak et al., 2021).

This is due to a school's low enrolment, which prevented the school from hiring enough teachers to teach the various subjects.

The incompetence of teachers, principals and parents

The three variables we have covered do not directly impact low performance since they cause **the** incompetence of teachers, principals and parents. This incompetence acts as a mediator; hence it causes low performance. Afterwards, teachers are the most important element of an administrative system; quality cannot be accomplished without them (Parveen & Tran, 2020). Hiring qualified teachers is the only way to provide high-quality education. the National Education Commission's (1959) guidelines, "no education system is better than its teachers." Teachers are the most important part of the educational system (Shahzad et al., 2013). Teachers cannot concentrate on their responsibilities if they are not sufficiently taught and receive PD. However, the impacts of leadership on student academic achievements are smaller and appear to function indirectly, as should be predicted given the importance of leaders, particularly the head teacher in schools (Highfield & Rubie-Davies, 2022). As a result, the key factors of a school's bad performance are illiteracy and poor leadership, a lack of academic staff accountability, and students' motivation (Parveen et al. 2021). According to the research, a parent's personality and lack of understanding were other reasons they did not carry out their duties. Parents may be uneducated or in control; some lack reading skills and cannot assist their children with their education, claims (Kiral,2020). The results indicate that parents did not carry out their duties. In a study on parents, Mupa & Chinooneka (2015) believe that parents are also responsible for their children's poor school performance and that parents with low education levels do not encourage their children's education. Therefore, families may be a

challenge for schools. All these incompetency factors related to teachers, Principals and Parents cause and contribute to the poor performance of students in public examinations.

METHODOLOGY

The study's goal was to look at the significant elements attributed to students' low performance in the secondary leaving examination, especially in the Benadir region of Somalia. The study focuses on deterrent elements, including school administrators, parents, and the incompetency mediator factor. In the study, a descriptive survey design was used. A questionnaire created by the researcher is the data gathering instrument. The study population was deduced from all the public and private secondary schools in Mogadishu, which are 603, based on the databases of Benadir Region's Education Department and Ministry of Education 2022. To ensure the sample's representativeness of private and public secondary schools, simple random sampling was used to choose a sample from the population. The sample consisted of 235 respondents. The sample size calculation is suitable for survey research with finite populations, according to the Krejcie and Morgan formulas, as cited by (Qureshi et al., 2021). The instrumentation was divided into two sections. Section A contained biographical information on the respondents, whereas Section B has 19 items about the various causes of low performance among students (SSCE). Experts in Tests and Measurement verified the questionnaire. Smart PLS 4.0 and SPSS 26.0 are used in this study to test the hypothesis and analyse the respondents' profiles, respectively. On a five-point Likert scale, respondents were asked to rate themselves. Qureshi et al., (2021) state that Likert scales are a frequent survey rating format.

Statistical technique

The Statistical Package for Social Sciences (IBM SPSS 26) was used in this study to summarise the demographics using descriptive statistical approaches, such as frequencies. Another statistical technique used to assess the path model's reliability, convergent validity, and discriminant validity is structural equation modelling (SEM-PLS) utilizing SMART PLS-4 software. Additionally, the bootstrapping method is used. As promoted for the technique by (Qureshi et al., 2021).

Demographics

Table 2 examines the age ranges, gender, education, and status of respondents. According to the results, 42.1% of the 235 respondents are under 30 years old, 37.0% are between 30 and 40, and 20.9% are 40 and above. Regarding gender, 80.4% of the 235 respondents were male, while 19.6% were female. In addition, the respondents' educational backgrounds were examined. According to the academic qualification, 20.4% of respondents were Diploma holders, 61.7% were undergraduates, and 17.9% were postgraduates

Table 1. Respondent's Profile (N=235).

Demographic items	Frequency	Percentile
Age		
Below 30	99	42.1
30 but below 40	87	37.0
40 and above	49	20.9
Gender		
Male	189	80.4
Female	46	19.6
Education		
Diploma	48	20.4
Bachelor	145	61.7
Master	42	17.9
Respondent Status		
School Principals	75	31.9
Teachers	80	34.0
Parents	80	34.0

Lastly, the respondent's status was examined. Participants in the survey consolidated that 31.9% of respondents were school principals, 34.0% were teachers, and 34.0% were parents.

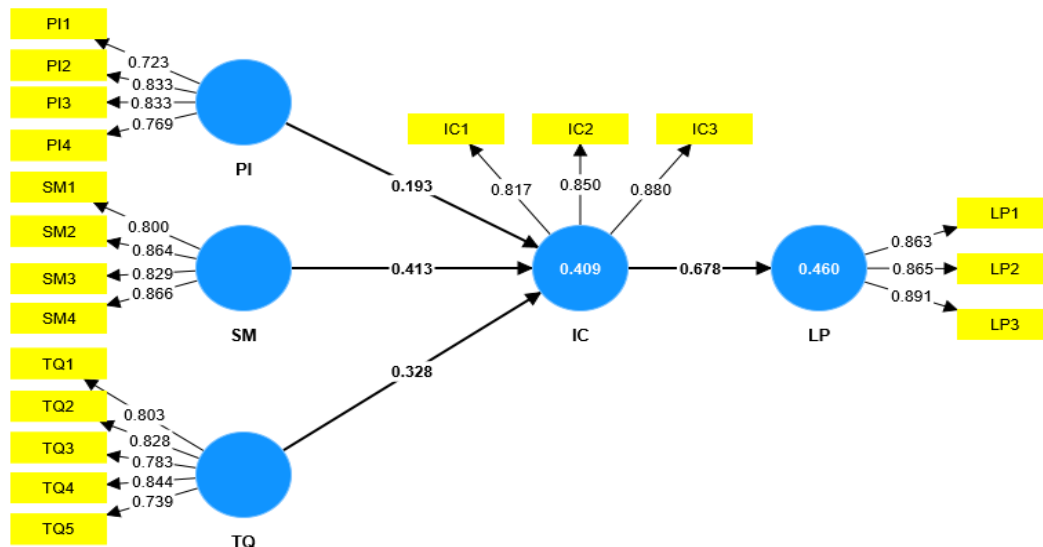

Figure 2. Measurement Model

Data analysis and results

The research data were analyzed using Lobo's (2022) Smart PLS-4 program. The statistical analysis is ideal for this investigation (Ji et al., 2021). The research model (PLS-SEM) was utilized to determine the measurement and structural model advocated by (Hair et al., 2020).

Measurement model

The study data was examined using the Smart PLS-4 program (Lobo, 2022). The statistical analysis is appropriate for this examination (Ji et al., 2021). The research model (PLS-SEM) was utilized to determine the measurement and structural model advocated by(Qureshi et al., 2021). As Liang et al. (2022) recommended, we tested the model in two steps. First, we used the measurement model to examine the validity and reliability of instruments using the rules set by the researchers ((Hair et al., 2019). Second, the structural model was then used to examine the hypotheses that had been developed. Smart PLS-4 was used to evaluate the loadings, average variance extracted (AVE), composite reliability (CR), bootstrap t-statistic (critical ratio), discriminant validity, and convergent validity.

Table 2. Measurement model

	Items	Loadings	Cronbach's alpha	Composite reliability	The average variance extracted (AVE)
Parent Involvement	PI1	0.723	0.805	0.833	0.625
	PI2	0.833			
	PI3	0.833			
	PI4	0.769			
School Management	SM1	0.8	0.861	0.866	0.706
	SM2	0.864			
	SM3	0.829			
	SM4	0.866			
Teacher Qualification	TQ1	0.803	0.862	0.888	0.641
	TQ2	0.828			
	TQ3	0.783			
	TQ4	0.844			
	TQ5	0.739			
Incompetency	IC1	0.817	0.807	0.808	0.722
	IC2	0.85			
	IC3	0.88			
Low Performance	LP	0.863	0.845	0.849	0.763
	LP	0.865			
	LP	0.891			

Note: PI, parent involvements; SM, school management; TQ, teacher qualification; IC, incompetency; LP, low performance.

As seen in Table 2, Cronbach's alpha, composite reliability, and average variance extracted are used to evaluate the convergent validity of the measured items (AVE). Using Cronbach's alpha, the survey items' internal consistency is assessed. The alpha value should be better than 0.7 to be considered acceptable (Qureshi et al., 2021). Additionally, "Composite reliability" and "AVE" were used to evaluate the reliability of the items. Hair et al. (2020) and Qureshi et al. (2021) advised loading values, AVEs, and CRs to be more than 0.5. According to Table 2, this study has met all three requirements.

Table 3. Discriminant validity

	PI	SM	TQ	IC	LP
PI	0.791				
SM	0.393	0.84			
TQ	0.088	0.074	0.8		
IC	0.384	0.513	0.375	0.85	
LP	0.366	0.507	0.207	0.678	0.873

Note: PI, parent involvements; SM, school management; TQ, teacher qualification; IC, incompetency; LP, low performance.

After convergent validity, cross-loadings, AVE, and HTMT were used to investigate discriminant validity. The first value of each construct should be bold because it represents the square root of "AVE." According to Hair et al. (2020), test, discriminant validity measures how much a latent variable distinguishes from other model variables. A construct is considered valid if its diagonal values are higher than its non-diagonal values in the associated columns and rows (Qureshi et al., 2021). Since all diagonal values are higher than non-diagonal values, discriminant validity has been established, as shown in Table 3. We then look at the cross-loadings. According to Table 4, each indicating variable had a greater loading in its related latent variable and high relevance to that latent variable. Additionally, it can be seen in Table 5 that the constructs have values not more than 0.85 or 0.9, indicating that they exhibit discriminant validity about the HTMT ratio.

Table 4. Cross loadings

	PI	SM	TQ	IC	LP
PI1	0.723	0.193	-0.023	0.182	0.233
PI2	0.833	0.272	0.135	0.354	0.323
PI3	0.833	0.331	0.11	0.351	0.258
PI4	0.769	0.43	-0.002	0.276	0.337
SM1	0.341	0.8	0.07	0.444	0.449
SM2	0.328	0.864	0.086	0.476	0.425
SM3	0.305	0.829	0.085	0.428	0.43
SM4	0.35	0.866	-0.006	0.359	0.392
TQ1	0.063	0.007	0.803	0.295	0.181
TQ2	0.075	0.107	0.828	0.307	0.171
TQ3	0.012	0.055	0.783	0.252	0.13
TQ4	0.083	0.069	0.844	0.39	0.222
TQ5	0.124	0.053	0.739	0.205	0.083
IC1	0.227	0.37	0.358	0.817	0.621
IC2	0.403	0.509	0.238	0.85	0.54
IC3	0.345	0.427	0.362	0.88	0.57
LP1	0.293	0.413	0.187	0.571	0.863
LP2	0.368	0.485	0.088	0.56	0.865
LP3	0.301	0.433	0.257	0.641	0.891

Note: PI, parent involvements; SM, school management; TQ, teacher qualification; IC, incompetency; LP, low performance.

Table 5. Heterotrait Monotrait Ratio (HTMT)

	PI	SM	TQ	IC	LP
PI					
SM	0.465				
TQ	0.114	0.102			
IC	0.453	0.608	0.434		
LP	0.442	0.593	0.225	0.821	

Note: PI, parent involvements; SM, school managements; TQ, teacher qualification; IC, incompetency; LP, low performance

The structural model is another aspect of SEM that relates latent variables to one another (Qureshi et al., 2021). The structural model identifies the patterns of relationships between the constructs (Qureshi et al., 2021). The bootstrap method can be used to obtain the outcome of a structural model. As a standardized regression coefficient (beta) and highlighting the direct effect of an independent variable on a dependent variable, the path coefficient in PLS-SEM examines the structural model and hypothesis. The bootstrapping approach was used with 5000 subsamples to test the relevance of path coefficients (Hair et al., 2020). The path-coefficient criterion states that the association is significant if the p-value is less than 0.01.

Table 6. Results of path analysis.

Hypothesis	Relationship	Beta	T values	P values	Decision
H1	PI -> IC	0.193	3.813	0	Accepted
H2	SM -> IC	0.413	7.051	0	Accepted
H3	TQ -> IC	0.328	5.554	0	Accepted
H4	IC -> LP	0.678	12.554	0	Accepted

Note: PI, parent involvements; SM, school management; TQ, teacher qualification; IC, incompetency; LP, Low Performance.

Table 6 indicates the path coefficient, t-statistics, p-value and significance level of 5%. In general, this study confirmed four proposed hypotheses. PI significantly improves incompetency factor IC ($\beta = 0.193$, t-statistic = 3.813, $p < 0.01$), which is consistent with Hypothesis 1. Given that SM significantly improves incompetency factor IC ($\beta = 0.413$, t-statistic = 7.051, $p < 0.01$), Hypothesis 2 is supported. Hypothesis 3 is reinforced by the discovery that TQ has a substantial affirmative influence on the incompetency factor ($\beta = 0.328$, t-statistic = 5.554, $p < 0.01$), as all p-values are less than 0.05. Moreover, the IC factor positively and significantly affects MF ($\beta = 0.678$, t-statistic = 12.554, $p < 0.01$). Hence H1, H2, H3, and H4, are accepted.

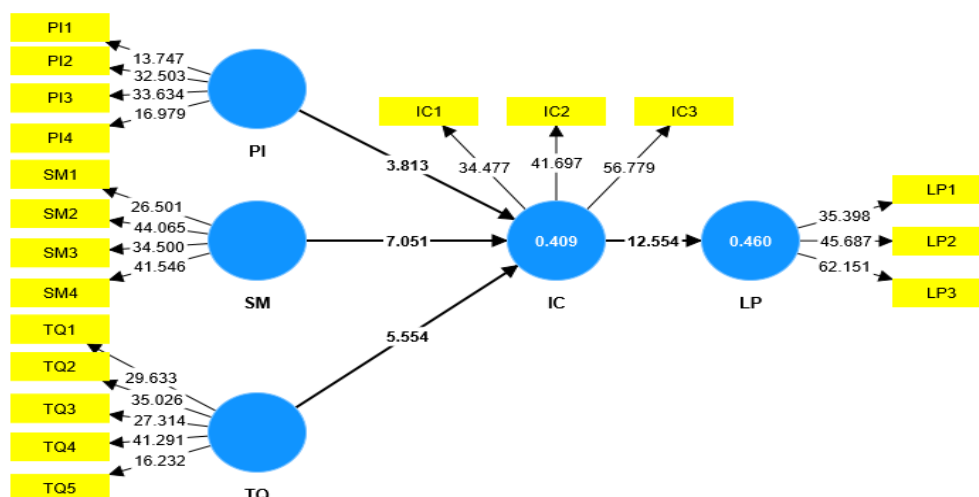

Figure 3. Results of path analysis

DISCUSSIONS

This study aimed to determine the key variables causing low performance in senior secondary school (SSCE) examinations in the Banadir region of Somalia. As previously stated, SEM analysis was used to examine the proposed hypotheses. The findings of this study validated and underlined the significance of four hypotheses, namely, parent involvements or PI (H1), school management or SM (H2), and teacher qualification or TQ (H3) and incompetency mediator factor or IC (H4), as shown in Figure 2. The findings supported all hypotheses. This study indirectly examines the relationship between all independent variables related to the dependent variable, corroborating earlier studies. However, the incompetency variable included in the model as a mediator variable had a significant association with the dependent variable, low student performance.

The first hypothesis concerns parental involvement with the incompetency mediator issue. The finding shows a significant positive connection ($\beta = 0.193$, $p < 0.01$). The study examines and analyses the extent to which parental factors contribute to the low performance of secondary school students. According to Zikanga et al. (2021), one of the biggest impediments to secondary education progress is the continual low performance of students in public examinations. Some reasons for this low performance include a lack of sufficient parental guidance, a failure to supply necessary materials for their children, and parents assisting in examination misconduct, among others. Another factor for parents failing to perform their tasks, according to the report, was their personality and lack of information. According to Kiral (2020), parents might be ignorant or dominating, and some parents lack reading skills and cannot assist their children with academics. According to Mupa and Chinooneka (2015), in a study conducted on parents, the findings suggest that parents did not fulfil their responsibilities and that parents with lower levels of education are unable to provide educational assistance to their children. As a result, families can be a barrier to education.

The second hypothesis is about school management, on the incompetency mediator factor. The result shows a significant positive relationship ($\beta = 0.413$, $p < 0.01$). This study aimed to determine the instructional role of school principals in secondary schools in the Banadir region of Somalia. According to the survey, school principals oversaw teachers' work by examining lesson books, schemes of work, records of work covered, attendance registers, and class attendance records, as well as working with their instructors and students by aiding them in teaching and learning. The statistics per category also demonstrated that head teachers perform poorly in their schools, contributing to the huge failure of secondary school students. However, the impacts of leadership on student academic achievements are smaller and appear to function indirectly, as should be predicted given the importance of leaders, particularly the head teacher in schools (Highfield & Rubie-Davies, 2022). As a result, the key factors of a school's bad performance are illiteracy and poor leadership, a lack of academic staff accountability, and students' motivation (Parveen et al. 2021).

The third hypothesis is about teacher qualification on the incompetency mediator factor. The result shows a significant positive relationship ($\beta = 0.328$, $p < 0.01$). The third research hypothesis is to determine how teacher factors contribute to the widespread failure of secondary school students' examinations in the Banadir region of Somalia. The findings reveal that a shortage of qualified teachers, out-of-field instruction, and ineffective teaching approaches contribute significantly to student failure. This is backed by W. Wamalwa et al. (2019), who believe the decline in academic achievement is due to teachers' failure to apply positive validation strategies. Quality cannot be accomplished without good teachers since teachers are the most important component of a country's administration system (Parveen & Tran, 2020). Only qualified teachers can provide quality education. According to the National Education Commission's principles (1959), "no education system is better than its teachers." According to Shahzad et al. (2013), teachers are the most serious aspect of the educational system. Teachers cannot concentrate on their duties if they are not well trained and receive regular professional development.

The fourth hypothesis concerns the incompetency mediator factor in the low performance of senior secondary school students' examinations. The result shows a significant positive relationship ($\beta = 0.678$, $p < 0.01$). This hypothesis has a direct impact on the low performance in senior secondary schools that are attributed to incompetency representatives' schools, which include inadequate school principals' instructional supervision of schools, a lack of cooperation between the school's leadership and the parents, a lack of parental involvement, a lack of qualified teachers, out-of-field teaching, and ineffective teaching methods, all of which cause and contribute to poor student performance in public examinations. The findings are consistent with those of Kiral (2020), Shahzad et al., (2013) and Highfield and Rubie-Davies, (2022).

CONCLUSION AND RECOMMENDATIONS

The main objective of this research was to identify the main causes contributing to large failures in senior secondary school (SSCE) examinations in the Banadir region of Somalia. The research backs up all of the model's relationships. The data revealed that the independent factors, parent participation, school management, and teacher qualification, all favoured the incompetency mediator factor. On the other hand, the incompetency mediator factor can positively affect the dependent variable, which predicts large failures in senior secondary school (SSCE) examinations. This study is being performed to investigate the low achievement levels of senior

secondary schools in Somalia's Banadir region. Since it has been argued that the high rates of failure in public examinations are observed yearly by the Ministry of Education, Culture, and Higher Education Office of the Minister (MOECHE) of the federal government of Somalia, when competent and qualified teachers are hired, student performance issues will be less of a problem. Training and retraining programs should also be organized for school administrators to increase their administrative capacity and provide students with better services. If academic performance is to be enhanced, seminars and workshops should be held for all parties involved to ensure that schools are given access to good and relevant learning material. If taken, all of these actions will go a long way toward resolving the issue of why Somali pupils in senior secondary school do poorly. In order to accomplish the desired educational goals, there is a need to enhance the working relationship between the ministry of education officials and school stakeholders, such as parents and teachers, through Parents Teachers' Associations (PTAs). All parties involved in the local school system are urged to collaborate effectively so that long-term solutions to the issues at hand can be found. It is the responsibility of the Somali government, through the Ministry of Education and, in particular, the department of Basic Education, to ensure that educational standards are met and upheld in all secondary schools. Since head teachers hardly ever reviewed the use of the academic documents created by instructors, internal curriculum supervision was ineffective; therefore, there is a need for headteachers to beef up academic supervision. Parents should be actively involved in their children's academic performance to play an important role. Parents should create a conducive home environment that gives their children enough time and space to study this will, in turn, help them easily monitor their children's academic performance and affect their success in school and leaving examinations. The study recommends that for the teacher shortage gap to be bridged, government or parental initiatives should be used to hire teachers in schools experiencing a severe teacher shortage to close this gap. All interested parties must participate in providing high-quality education, including parents, who must be willing to contribute to the expense of that education. Lastly, the study recommends stepping up teacher training seminars to assist educators in developing a positive attitude regarding teaching in secondary schools; this, in turn, will enable the teachers to counsel students on developing a good learning attitude.

REFERENCE

1. Anastasiou, S., & Papagianni, A. (2020). Parents', teachers' and principals' views on parental involvement in secondary education schools in Greece. *Education Sciences*, 10(3). <https://doi.org/10.3390/educsci10030069>
2. Aremu, O. A., Tella, A., & Tella, A. (2006). Relationship among emotional intelligence, parental involvement and academic achievement of secondary school students in Ibadan, Nigeria. *Essays in Education*, 18.
3. Casian, M., Mugo, L., & Mukamazimpaka, M. C. (2021). Impact of Teacher' Qualification on Students' Academic Performance in Public Secondary Schools in Rwanda. *Journal of Education*, 4(2), 75-88.
4. Co, A. G. E., Abella, C. R. G., & Jesus, F. S. De. (2021). Teaching Outside Specialization from the Perspective of Science Teachers. *OALib*, 08(08), 1-13. <https://doi.org/10.4236/oalib.1107725>
5. Haile, M. (2021). Teachers' Perceptions of Junior Secondary Education and Student Academic Performance in Central Ethiopia Walden University.
6. Hair, J. F., Howard, M. C., & Nitzl, C. (2020). Assessing measurement model quality in PLS-SEM using confirmatory composite analysis. *Journal of Business Research*, 109, 101-110. <https://doi.org/https://doi.org/10.1016/j.jbusres.2019.11.069>
7. Hair, J. F., Risher, J. J., Sarstedt, M., & Ringle, C. M. (2019). When to use and how to report the results of PLS-SEM. *European Business Review*, 31(1), 2-24. <https://doi.org/10.1108/EBR-11-2018-0203>
8. Hassan, A., Bisaso, S. M., Ssekanyo, I., & Kantono, R. (2020). Academic Performance in Islamic University Primary School: Causes of Poor Performance and Anticipated Remedy. A Study Commissioned by the Executive Board of Islamic University in Uganda. *East African Journal of Education Studies*, 2(1), 105-114. <https://doi.org/10.37284/eajes.2.1.210>
9. Highfield, C., & Rubie-Davies, C. (2022). Middle leadership practices in secondary schools associated with improved student outcomes. *School Leadership and Management*, October, 1-22. <https://doi.org/10.1080/13632434.2022.2137126>
10. Isaac, E., Chukwudi, D., & Harcourt, N. P. (2022). Relationship between Emotional Intelligence and Academic Performance of Students of Public Senior Secondary Schools in Rivers State. 10(1), 81-89.
11. Islam, F., Id, S., Development, E., Leadership, E., & Islam, F. (2021). The Scenario Of " Parents Involvement " In Government Primary Schools In Lalbag.

12. Jabar, M., Kasilag, R., Collado, Z., & Jamoral, R. (2021). Family capital and parental involvement among parents in public elementary and secondary schools in the Philippines: perspectives of parents and children. *Asia Pacific Journal of Education*, 00(00), 1-17. <https://doi.org/10.1080/02188791.2021.1944841>
13. Ji, R., Yue, X., & Zheng, X. (2021). Using PLS-SEM to Examine the Structure of First-year University Students' Mathematics-related Beliefs. *Higher Education Studies*, 11(4), 7. <https://doi.org/10.5539/hes.v11n4p7>
14. Kiral, B. (2020). A case study regarding of the parental responsibilities to their children. *Eurasian Journal of Educational Research*, 2020(85), 65-92. <https://doi.org/10.14689/ejer.2020.85.4>
15. Klein, E. D., & Schwanenberg, J. (2022). Ready to lead school improvement? Perceived professional development needs of principals in Germany. *Educational Management Administration and Leadership*, 50(3), 371-391. <https://doi.org/10.1177/1741143220933901>
16. Liang, D., Lau, N., & Antin, J. (2022). A Structural Equation Model of Older Adults' Driving Exposure and Avoidance Using Objective Driving Records. *Proceedings of the Human Factors and Ergonomics Society Annual Meeting*, 66(1), 6-7.
17. Linda, A. (2022). the Effect of Flip Chart on Vocabulary Learning Outcomes At the 8Th Grade Students of Smp Negeri 1 Tarub Tegal Regency.
18. Lobo, J. (2022). The Mediating Role of Perceived Instructor ' s Emotional Support to Students ' Academic Resiliency and School Engagement. 1-21.
19. Lumadede, H. U., Shiundu, J. O., & Poipoi, M. W. (2020). Teachers' Perceptions of the Role of Examination on Students' Academic Achievement in Public Secondary Schools, Kakamega County, Kenya. *IOSR Journal Of Humanities And Social Science (IOSR-JHSS)*, 25(5), 35. <https://doi.org/10.9790/0837-2505093552>
20. Makau, N. N., Tanui, E., & Ronoh, A. (2016). Comparison between the instructional leadership practices of principals in high and low performing schools. *International Journal of Current Research*, 8(11), 41381-41386.
21. Muhammad, A., Nurman, Y., Illahi, R., & Alimuddin, K. (2020). A Study of the Principal ' s Leadership Role on Teacher ' s Performance in Tonra State Senior High School 1 , Bone Regency of the South Sulawesi Province , Indonesia . 3(2), 35-44.
22. Mupa, P., & Chinooneka, T. I. (2015). Factors contributing to ineffective teaching and learning in primary schools: Why are schools in decadence? *Journal of Education and Practice*, 6(19), 125-132.
23. Nazir, J., Rahaman, S., Chunawala, S., Ahmed, G., Alzoubi, H., Alshurideh, M., & AlHamad, A. (2022). Perceived Factors Affecting Students Academic Performance. *Academy of Strategic Management Journal*, 21(4), 1-15.
24. Neuenschwander, M. P. (2020). Information and Trust in Parent-Teacher Cooperation - Connections with Educational Inequality. *Central European Journal of Educational Research*, 2(3), 19-28. <https://doi.org/10.37441/cejer/2020/2/3/8526>
25. Noor, T., & Nawab, A. (2022). Are school leaders working as instructional leaders? Exploration of school leadership practices in rural Pakistan. *Cogent Education*, 9(1), 2109315.
26. Ogunode, N. (2022). An Investigation on Impact of Secondary School Administration on Teachers' Job and Students Academic Performance in Federal Capital, Abuja. *Academic Journal of Digital ...*, 14(c), 36-41. <http://economics.academicjournal.io/index.php/economics/article/view/415%0Ahttp://economics.academicjournal.io/index.php/economics/article/download/415/400>
27. Oludipe, D. I., & Oludipe, B. D. (2021). Do Teachers' Qualifications and Experience Influence Academic Performance of Students in Basic Science in Junior Secondary Schools in Nigeria? *Journal of Education in Black Sea Region*, 6(2), 148-164. <https://doi.org/10.31578/jeps.v6i2.239>
28. Owan, V. J., & Agunwa, J. N. (2019). Principals' administrative competence and teachers' work performance in secondary schools in calabar education zone of Cross River State, Nigeria. *Humanities and Social Sciences Letters*, 7(1), 20-28. <https://doi.org/10.18488/journal.73.2019.71.20.28>
29. Papakitsos, E. (2022). The Parental Involvement in a Multicultural Educational Context. 6(1). <https://www.researchgate.net/publication/361241005>
30. Parveen, K., Quang, T., Phuc, B., Shafiq, M., & Wei, T. X. (2021). Identifying the administrative challenges encountered by the principals in low - performing public secondary schools of Faisalabad District , Pakistan. 4(1), 5-16.

31. Parveen, K., & Tran, P. Q. B. (2020). Practical problems for low quality education and steps needed for investment in public schools of Pakistan. *Journal of Social Sciences Advancement*, 1(01), 01-07. <https://doi.org/10.52223/jssa20-010101-01>
32. Paul, R., Rashmi, R., & Srivastava, S. (2021). Does lack of parental involvement affect school dropout among Indian adolescents? evidence from a panel study. *PLoS ONE*, 16(5 May 2021), 1-16. <https://doi.org/10.1371/journal.pone.0251520>
33. Purnomo, H., Mansir, F., Tumin, T., & Suliswiyadi, S. (2020). Pendidikan Karakter Islami Pada Online Class Management di SMA Muhammadiyah 7 Yogyakarta Selama Pandemi Covid-19. *Jurnal Tarbiyatuna*, 11(1), 91-100. <https://doi.org/10.31603/tarbiyatuna.v11i1.3456>
34. Qureshi, M. A., Khaskheli, A., Qureshi, J. A., Raza, S. A., & Yousufi, S. Q. (2021). Factors affecting students' learning performance through collaborative learning and engagement. *Interactive Learning Environments*, 0(0), 1-21. <https://doi.org/10.1080/10494820.2021.1884886>
35. Razak, W. A. I. B. W. A., Akmal, S. N. A. B. K., Akmal, S. N. A. B. K., Wani, S., Hamal, A. Q., & Muhammad, A. H. (2021). Factors Affecting Student ' s Academic Performance. *International Journal on Perceptive and Cognitive Computing (IJPC)*, 7(1), 99-107.
36. Shahzad, S., Qadeer, Z., & Khan, H. (2013). Quality of instruction at secondary level. *International Journal of Physical and Social Sciences*, 3(9), 70-82.
37. Tenenhaus, M., Vinzi, V., Chatelin, Y. M., & Lauro, C. (2005). Partial least squares. *Computational Statistics & Data Analysis*, 48(1), 159-205.
38. Tuan, K. M., Hoan, T. H., Hoang Yen, D. T., & Huyen, N. P. (2022). Implementation of blended learning in professional development programmes for school principals: factors affecting the satisfaction of principals from disadvantaged areas in Vietnam. *Learning: Research and Practice*, 00(00), 1-21. <https://doi.org/10.1080/23735082.2022.2083217>
39. W. Wamalwa, E., A. Mugasia, F., & K. Sugut, W. (2019). Poor Performance in National Examinations by Public Primary Schools in Kakamega North Sub-County, Kenya. *Journal of Education & Social Policy*, 6(2). <https://doi.org/10.30845/jesp.v6n2p14>
40. Widiastara, B., & Andriani, D. E. (2020). The Effects of Instructional Leadership and Organizational Culture on Teacher Performance at Public Senior High Schools in Sleman Regency , Indonesia. <https://doi.org/10.4108/eai.19-12-2020.2309164>
41. Wilkesmann, Z. N. (2021). Influence of Motivation on Academic Performance of Students in Germany. *Journal of Education*, 4(6), -. <https://doi.org/10.53819/810181025018>
42. Zikanga, D. K., Anumaka, B. I., Tamale, M. B., & Mugizi, W. (2021). Remuneration and Job Performance of Teachers in Government Aided Secondary Schools in Western Uganda. *Interdisciplinary Journal of Education Research*, 3(2), 10-22. <https://doi.org/10.51986/ijer-2021.vol3.02.02>