



## Quasi-interpolation by $C^1$ quartic splines on type-1 triangulations

D. Barrera <sup>a,\*</sup>, C. Dagnino <sup>b</sup>, M.J. Ibáñez <sup>a</sup>, S. Remogna <sup>b</sup>

<sup>a</sup> Department of Applied Mathematics, University of Granada, Campus de Fuentenueva s/n, 18071 Granada, Spain

<sup>b</sup> Department of Mathematics, University of Torino, via C. Alberto, 10, 10123 Torino, Italy



### ARTICLE INFO

#### Article history:

Received 24 January 2018

Received in revised form 23 May 2018

#### Keywords:

Spline approximation

Quasi-interpolation

Bernstein–Bézier form

Type-1 triangulation

### ABSTRACT

In this paper we construct two new families of  $C^1$  quartic quasi-interpolating splines on type-1 triangulations approximating regularly distributed data. The splines are directly determined by setting their Bernstein–Bézier coefficients to appropriate combinations of the given data values instead of defining the approximating splines as linear combinations of compactly supported bivariate spanning functions and do not use prescribed derivatives at any point of the domain. The quasi-interpolation operators provided by the proposed schemes interpolate the data values at the vertices of the triangulation, reproduce cubic polynomials and yield approximation order four for smooth functions. We also propose some numerical tests that confirm the theoretical results.

© 2018 Elsevier B.V. All rights reserved.

## 1. Introduction

The spline quasi-interpolation has been the subject of extensive research since its introduction. The fundamental reason is that it constitutes a simple procedure for constructing spline approximations of functions from specific information about them, such as the point values of the function to be approximated and some of its derivatives [1].

In general, given a space of functions  $\mathcal{S}$  a quasi-interpolation operator (QIO)  $\mathcal{Q}$  for  $\mathcal{S}$  is a linear map into  $\mathcal{S}$  which is local, bounded (in some relevant norm), and reproduces some (nontrivial) polynomial space [2, p. 10]. Usually,  $\mathcal{S}$  is the space spanned by the translates on a lattice of a nonnegative function with compact support that provide a partition of unity. B-splines and box splines are very relevant choices (see [2–7] and references therein). These functions have been used to define different quasi-interpolants having specific properties, among them the near-minimality of the infinity norm of the operator. The univariate case is considered in [8–10]. This kind of construction in the bivariate case has been addressed in [11–14], and the trivariate case has been considered in [15–18]. Not only B-splines and box splines have been used to define quasi-interpolants. For instance, in [19] the construction of QIOs for the space of quadratic Powell–Sabin splines on nonuniform triangulations is considered (see also [20–22]). As said before, a QIO reproduces a space of polynomials. However, it is also possible to define quasi-interpolation projectors, as done, for instance, in [23,24].

A different approach has been adopted in a few papers since 2005 for defining  $C^1$  quasi-interpolants [25–27]. It is based on the Bernstein–Bézier representation of polynomials on triangular and tetrahedral partitions. The idea of this approach is to set all the Bernstein–Bézier (BB-) coefficients of the splines by using local portions of the data in such a way that the  $C^1$ -smoothness conditions are satisfied as well as the reproduction of the polynomials of appropriate total degrees. Hence, each polynomial piece of the approximating spline is immediately available from local portions of the data, without using

\* Corresponding author.

E-mail addresses: [dbarrera@ugr.es](mailto:dbarrera@ugr.es) (D. Barrera), [catterina.dagnino@unito.it](mailto:catterina.dagnino@unito.it) (C. Dagnino), [mibanez@ugr.es](mailto:mibanez@ugr.es) (M.J. Ibáñez), [sara.remogna@unito.it](mailto:sara.remogna@unito.it) (S. Remogna).

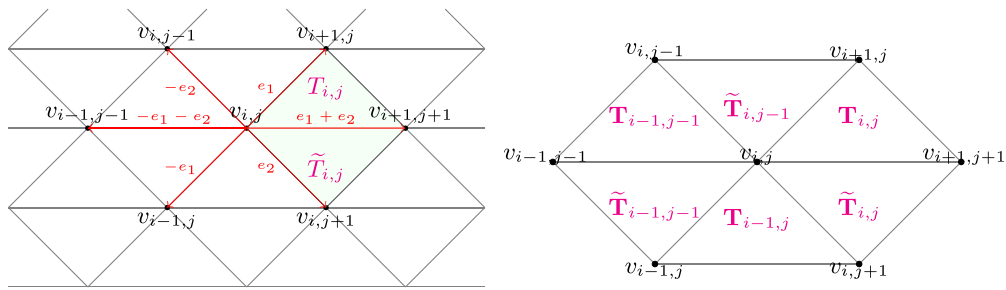

Fig. 1. The triangulation  $\Delta$  (left) and the hexagon  $H_{i,j}$  (right).

prescribed derivatives at any point of the domain. In [25], a QIO for the space of  $C^1$  quadratic splines on a type-2 triangulation of a rectangular domain is defined. It is exact on the space  $\mathbb{P}_2$  of polynomials of total degree two. A similar methodology is used in [27] to define a QIO for the space of  $C^1$  quartic splines on a type-1 triangulation of the real plane, that reproduces the space  $\mathbb{P}_3$  of cubic polynomials. Finally, in [26] a QIO for the space of  $C^1$  cubic on a type-6 tetrahedral partition of a rectangular, volumetric domain, that reproduces trilinear polynomials. In all cases the proposed quasi-interpolants only use data values, and simultaneously approximate smooth functions as well as their derivatives.

The main goal of this paper is to extend the results in [27], proposing new QIOs with less computational cost and a smaller uniform norm. Moreover, we recall that the space  $S_k^\rho(\Delta)$  of piecewise polynomials of degree  $\leq k$  and smoothness  $\rho$  on a three-directional mesh  $\Delta$  has the same approximation order that  $S_{loc}$  does, where  $S_{loc}$  is the span of box splines contained in  $S_k^\rho(\Delta)$  [28]. In particular, in [29] (see also [30]), it has been proved that the approximation order of  $S_k^\rho(\Delta)$  is at best  $k$  when  $k < 3\rho + 2$ ,  $\rho > 0$ . From the above result, we get that the spaces of  $C^1$  and  $C^2$  quartic splines have the same approximation order four. Good QIOs based on  $C^2$  box splines having quite small uniform norms are well-known. They provide  $C^2$  quartic quasi-interpolating splines directly and it is possible to compute the BB-coefficients of their restrictions to every triangle in the triangulation. However, some reasons to choose working with  $C^1$  splines are in order. If a  $C^2$  quartic box spline is used to define the QIO by its integer translates, then the BB-coefficients of a quasi-interpolating spline on every triangle  $T$  are combinations of the values of the approximated functions at the vertices lying in a large neighborhood of  $T$ . On the contrary, in the case of dealing with  $C^1$  quartic splines the BB-coefficients are computed from simple averaging rules to the data in  $T$  and in the immediate neighboring to  $T$  triangles. The coefficients of those rules do not depend on the triangulation due to its uniform structure. Moreover, in the  $C^1$  case, it will be possible to define QIOs with smaller infinity norm and the quasi-interpolants will be interpolatory at the vertices. In addition, the computational cost can be halved with respect to the operator defined in [27].

Finally, as quoted in [31], in practice the  $C^1$  scheme in [27] provides the best tradeoff between smoothness and the number of polynomial patches used to represent a data set when modeling surfaces of high geometric complexity, such as large-scale terrain models.

Here is an outline of the paper. In Section 2, we give some preliminaries on the BB-form of quartic  $C^1$ -splines on type-1 triangulations and we introduce some useful notations used throughout the paper. In Sections 3 and 4, we define families of quasi-interpolating splines based on two different sets of points. We analyze the general schemes, depending on a certain number of free parameters and we present some strategies in order to fix them. For a particular choice of the parameters, we obtain the spline in [27]. Moreover, we discuss the approximation properties of the corresponding operators. Finally, in Section 5, we propose some numerical tests that confirm the theoretical results established in the previous sections.

## 2. Notations and preliminaries

This work aims to analyze the construction in [27] in order to provide new quasi-interpolation schemes. Thus, although it is possible to use any type-1 triangulation, we consider the one defined by the directions  $e_1 := (h, h)$ ,  $e_2 := (h, -h)$  and  $e_3 = e_1 + e_2$ , with  $h > 0$ , and the notations in the referred paper to facilitate the comparison of results. The vertices of such a partition  $\Delta$  are defined as  $v_{i,j} := ie_1 + je_2$ ,  $i, j \in \mathbb{Z}$ . They define the two-dimensional lattice  $\mathcal{V} := \{v_{i,j} : i, j \in \mathbb{Z}\}$ , that subdivides the plane into equal parallelograms  $P_{i,j} := [v_{i,j}, v_{i,j+1}, v_{i+1,j+1}, v_{i+1,j}]$  (see Fig. 1(left)). Each parallelogram  $P_{i,j}$  is split into two triangles  $T_{i,j} := [v_{i,j}, v_{i+1,j}, v_{i+1,j+1}]$  and  $\tilde{T}_{i,j} := [v_{i,j}, v_{i,j+1}, v_{i+1,j+1}]$ , by drawing the diagonal  $[v_{i,j}, v_{i+1,j+1}]$ . Therefore, the triangulation  $\Delta$  is defined in this way  $\Delta := \bigcup_{i,j \in \mathbb{Z}} (T_{i,j} \cup \tilde{T}_{i,j})$ . The triangulation  $\Delta$  can also be viewed as a collection of overlapping hexagons, as shown in Fig. 1(right), where  $H_{i,j}$  is the hexagon centered at  $v_{i,j}$ .

We will construct quasi-interpolating splines in  $S_4^1(\Delta) := \{s \in C^1(\mathbb{R}^2) : s|_T \in \mathbb{P}_4, \text{ for all } T \in \Delta\}$ , where  $\mathbb{P}_4 := \text{span}\{x^i y^j : 0 \leq i + j \leq 4\}$  is the space of bivariate polynomials of total degree four. Such splines will be defined by directly setting their BB-coefficients on the triangles of  $\Delta$  (see e.g. [5]). Given a function  $s \in S_4^1(\Delta)$ , its restriction to a triangle  $T = [v_0, v_1, v_2] \in \Delta$  can be written as

$$s|_T = \sum_{i+j+k=4} c_{i,j,k}^T B_{i,j,k}^T,$$

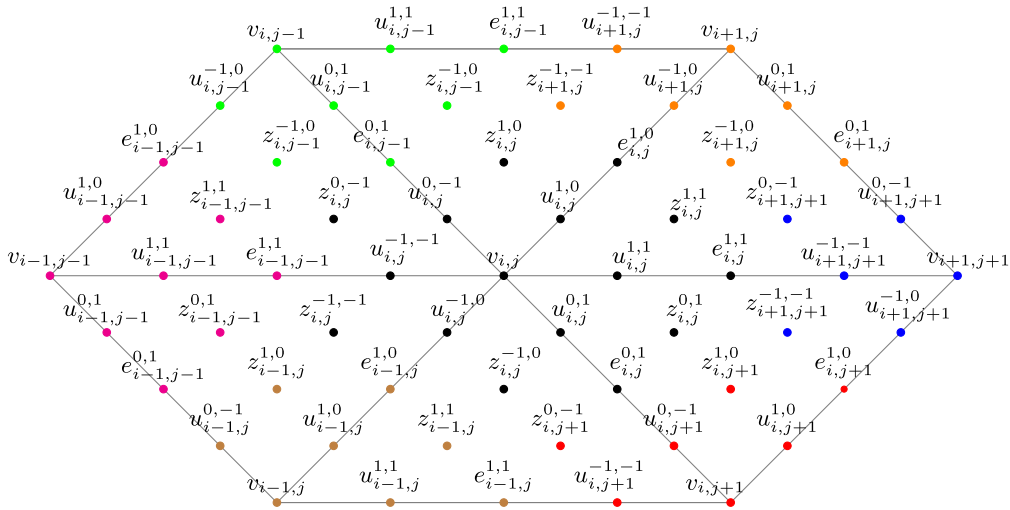

Fig. 2. The points of  $\mathcal{D}_4$  relative to  $H_{i,j}$ .

where  $B_{i,j,k}^T := \frac{4!}{i!j!k!} b_0^i b_1^j b_2^k, i, j, k \geq 0, i+j+k = 4$ , are the Bernstein polynomials of degree 4 associated with  $T$  and  $(b_0, b_1, b_2)$  are the barycentric coordinates with respect to  $T$ , i.e.  $(x, y) = b_0 v_0 + b_1 v_1 + b_2 v_2, b_0 + b_1 + b_2 = 1$  for  $(x, y) \in T$ .

We associate the BB-coefficients  $c_{i,j,k}^T$  of  $s_{|T}$  relative to  $T$  with the domain points  $\xi_{i,j,k}^4 := (iv_0 + jv_1 + kv_2) / 4$  in  $T$ . The union, without repetitions, of all domain points of each triangle in  $\Delta$  gives rise to set denoted by  $\mathcal{D}_4$ . For the construction of our quasi-interpolating splines, we also consider the subsets  $\mathcal{D}_3$  and  $\mathcal{D}_2$ , where  $\mathcal{D}_3$  ( $\mathcal{D}_2$ ) denotes the union, without repetitions, of the sets of domain points for a cubic (quadratic) polynomial associated with each triangle  $T$  in  $\Delta$ :  $\xi_{i,j,k}^3 := (iv_0 + jv_1 + kv_2) / 3$  ( $\xi_{i,j,k}^2 := (iv_0 + jv_1 + kv_2) / 2$ ).

As in [27], the proposed construction is based on an appropriate partition  $\{\mathcal{D}_{i,j}^\ell, i, j \in \mathbb{Z}\}$  of  $\mathcal{D}_\ell, \ell = 2, 3, 4$ :

- $\mathcal{D}_{i,j}^4 := \{v_{i,j}\} \cup \{e_{i,j}^{k,m}, k, m \in \{0, 1\}, k+m \neq 0\} \cup \{u_{i,j}^{k,m}, z_{i,j}^{k,m}, k, m \in \{-1, 0, 1\}, k+m \neq 0\}$ , where  $e_{i,j}^{k,m}$  is the midpoint of  $[v_{i,j}, v_{i+k,j+m}]$ ,  $u_{i,j}^{k,m} := \frac{1}{4}(3v_{i,j} + v_{i+k,j+m})$ ,  $z_{i,j}^{k,m} := \frac{1}{4}(2v_{i,j} + v_{i+k,j+m} + v_{r,s})$ , with  $v_{r,s}$  the third vertex of  $[v_{i,j}, v_{i+k,j+m}, v_{r,s}] \in \Delta$  counting counterclockwise;
- $\mathcal{D}_{i,j}^3 := \{v_{i,j}, t_{i,j}, \tilde{t}_{i,j}\} \cup \{w_{i,j}^{k,m}, k, m \in \{-1, 0, 1\}, k+m \neq 0\}$ , where  $t_{i,j}$  and  $\tilde{t}_{i,j}$  are the barycenters of  $T_{i,j}$  and  $\tilde{T}_{i,j}$ , respectively,  $w_{i,j}^{k,m} := \frac{1}{3}(2v_{i,j} + v_{i+k,j+m})$ ,
- $\mathcal{D}_{i,j}^2 := \{v_{i,j}, e_{i,j}^{1,0}, e_{i,j}^{0,1}, e_{i,j}^{1,1}\}$ .

Therefore,  $\mathcal{D}_\ell = \bigcup_{i,j} \mathcal{D}_{i,j}^\ell, \ell = 2, 3, 4$ . Figs. 2–4 show the domain points in  $\mathcal{D}_\ell, \ell = 4, 3, 2$ , lying in the hexagon  $H_{i,j}$ , respectively.

### 3. $C^1$ quartic quasi-interpolating splines based on $\mathcal{D}_3$ point values

Once introduced the needed notations, we define and analyze two different quasi-interpolating splines  $Q_{4,\ell} f \in S_4^1(\Delta), \ell = 2, 3$ , for a given function  $f \in C(\mathbb{R}^2)$ , by assuming to know the values of  $f$  on  $\mathcal{D}_\ell$ .

Firstly, we describe the construction of the spline  $Q_{4,3} f \in S_4^1(\Delta)$  from the values  $f(v), v \in \mathcal{D}_3$ , by setting its BB-coefficients on each triangle  $T \in \Delta$ , taking into account that  $\Delta$  is a uniform triangulation. For example, we write the restriction of  $Q_{4,3} f$  to the triangle  $T_{i,j}$  as

$$\begin{aligned}
 Q_{4,3} f|_{T_{i,j}} &= c(v_{i,j}) B_{4,0,0}^{T_{i,j}} + c(u_{i,j}^{1,1}) B_{3,1,0}^{T_{i,j}} + c(u_{i,j}^{1,0}) B_{3,0,1}^{T_{i,j}} + c(e_{i,j}^{1,1}) B_{2,2,0}^{T_{i,j}} + c(z_{i,j}^{1,1}) B_{2,1,1}^{T_{i,j}} \\
 &+ c(e_{i,j}^{1,0}) B_{2,0,2}^{T_{i,j}} + c(u_{i+1,j+1}^{-1,-1}) B_{1,3,0}^{T_{i,j}} + c(z_{i+1,j+1}^{0,-1}) B_{1,2,1}^{T_{i,j}} + c(z_{i+1,j}^{-1,0}) B_{1,1,2}^{T_{i,j}} \\
 &+ c(u_{i+1,j}^{-1,0}) B_{1,0,3}^{T_{i,j}} + c(v_{i+1,j+1}) B_{0,4,0}^{T_{i,j}} + c(u_{i+1,j+1}^{0,-1}) B_{0,3,1}^{T_{i,j}} + c(e_{i+1,j}^{0,1}) B_{0,2,2}^{T_{i,j}} \\
 &+ c(u_{i+1,j}^{0,1}) B_{0,1,3}^{T_{i,j}} + c(v_{i+1,j}) B_{0,0,4}^{T_{i,j}},
 \end{aligned} \tag{3.1}$$

with  $c(p)$  denoting the BB-coefficient associated with the domain point  $p \in \mathcal{D}_{i,j}^4$ .

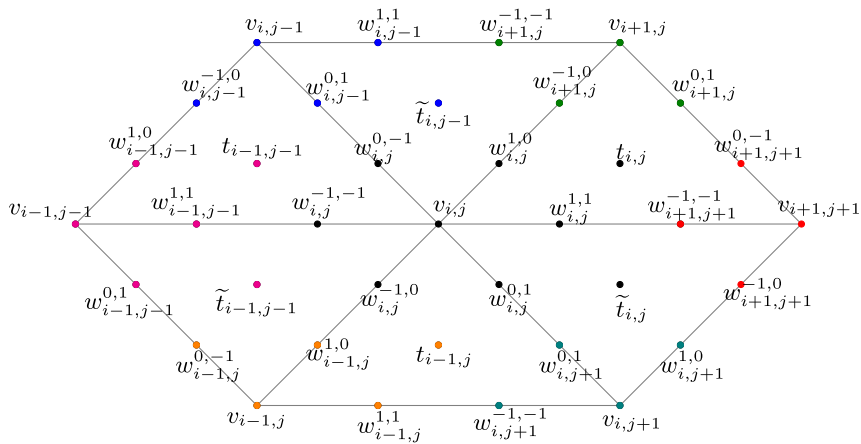

Fig. 3. The points of  $\mathcal{D}_3$  relative to  $H_{i,j}$ .

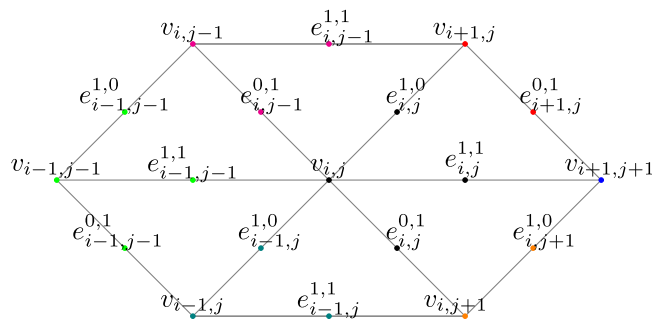

Fig. 4. The points of  $\mathcal{D}_2$  relative to  $H_{i,j}$ .

Thanks to symmetry, it is sufficient to determine the setting of the BB-coefficients corresponding to one of the domain points denoted by the letters  $v, u, e$  and  $z$  in  $\mathcal{D}_4$ . The other ones can be obtained by translation and/or rotation.

Let  $c(v_{i,j}) := f(v_{i,j})$ . The BB-coefficients corresponding to the domain points denoted by the letters  $u, e$  and  $z$ , are expressed as linear combination of the values of  $f$  at the 37 domain points of  $\mathcal{D}_3$  lying in  $H_{i,j}$  (see Fig. 3). For example, the BB-coefficient associated with the domain point  $u_{ij}^{1,1}$  has the following form

$$\begin{aligned}
 c(u_{ij}^{1,1}) = & \omega_0 f(v_{ij}) + \omega_1 f(w_{ij}^{1,1}) + \omega_2 f(w_{ij}^{1,0}) + \omega_3 f(w_{ij}^{0,-1}) + \omega_4 f(w_{ij}^{-1,-1}) + \omega_5 f(w_{ij}^{-1,0}) + \omega_6 f(w_{ij}^{0,1}) \\
 & + \omega_7 f(w_{i+1,j+1}^{-1,-1}) + \omega_8 f(t_{ij}) + \omega_9 f(w_{i+1}^{-1,0}) + \omega_{10} f(\tilde{t}_{i,j-1}) + \omega_{11} f(w_{i,j-1}^{0,1}) + \omega_{12} f(t_{i-1,j-1}) \\
 & + \omega_{13} f(w_{i-1,j-1}^{1,1}) + \omega_{14} f(\tilde{t}_{i-1,j-1}) + \omega_{15} f(w_{i-1,j}^{1,0}) + \omega_{16} f(t_{i-1,j}) + \omega_{17} f(w_{i,j+1}^{0,-1}) + \omega_{18} f(\tilde{t}_{ij}) \\
 & + \omega_{19} f(v_{i+1,j+1}) + \omega_{20} f(w_{i+1,j+1}^{0,-1}) + \omega_{21} f(w_{i+1,j}^{0,1}) + \omega_{22} f(v_{i+1,j}) + \omega_{23} f(w_{i+1,j}^{-1,-1}) + \omega_{24} f(w_{i,j-1}^{1,1}) \\
 & + \omega_{25} f(v_{i,j-1}) + \omega_{26} f(w_{i,j-1}^{-1,0}) + \omega_{27} f(w_{i-1,j-1}^{1,0}) + \omega_{28} f(v_{i-1,j-1}) + \omega_{29} f(w_{i-1,j-1}^{0,1}) + \omega_{30} f(w_{i-1,j}^{0,-1}) \\
 & + \omega_{31} f(v_{i,j-1}) + \omega_{32} f(w_{i-1,j}^{1,1}) + \omega_{33} f(w_{i,j+1}^{-1,-1}) + \omega_{34} f(v_{i,j+1}) + \omega_{35} f(w_{i,j+1}^{1,0}) + \omega_{36} f(w_{i+1,j+1}^{-1,0}).
 \end{aligned}$$

In order to simplify the notations, let  $f_{i,j}(\mathcal{D}_3) \in \mathbb{R}^{37}$  be the vector of the values of  $f$  at the 37 domain points of  $\mathcal{D}_3$  lying in  $H_{i,j}$ , enumerated as in Fig. 5 (left), and let  $\omega \in \mathbb{R}^{37}$  be the vector whose elements are enumerated in the same way. We call  $\omega$  a mask. Therefore, we write  $c(u_{ij}^{1,1}) = f_{i,j}(\mathcal{D}_3) \cdot \omega$ , where  $A \cdot B := \sum_{k=1}^n A_k B_k$ , with  $n$  the cardinality of  $A$  and  $B$ . The BB-coefficients associated with the other  $u$ -points ( $u_{ij}^{1,0}, u_{ij}^{0,-1}, u_{ij}^{-1,-1}, u_{ij}^{-1,0}$ , and  $u_{ij}^{0,1}$ ) are defined in a similar way but using the rotated versions of the mask  $\omega$ .

Analogously, the BB-coefficients  $c(e_{i,j}^{1,1})$  and  $c(z_{i,j}^{1,1})$  are defined by considering the masks  $\alpha$  and  $\beta$ , respectively  $c(e_{i,j}^{1,1}) = f_{i,j}(\mathcal{D}_3) \cdot \alpha$ ,  $c(z_{i,j}^{1,1}) = f_{i,j}(\mathcal{D}_3) \cdot \beta$ . The BB-coefficients associated with the other  $e, z$ -points are defined from the rotated versions of  $\alpha$  and  $\beta$ .

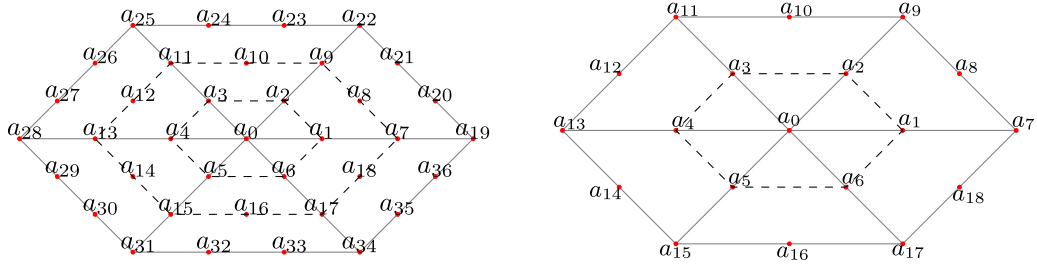

Fig. 5. Notation used for enumerate  $f_{i,j}(\mathcal{D}_\ell)$ ,  $\alpha$ ,  $\beta$ ,  $\omega$  in case  $\ell = 3$  (left) and  $\ell = 2$  (right).

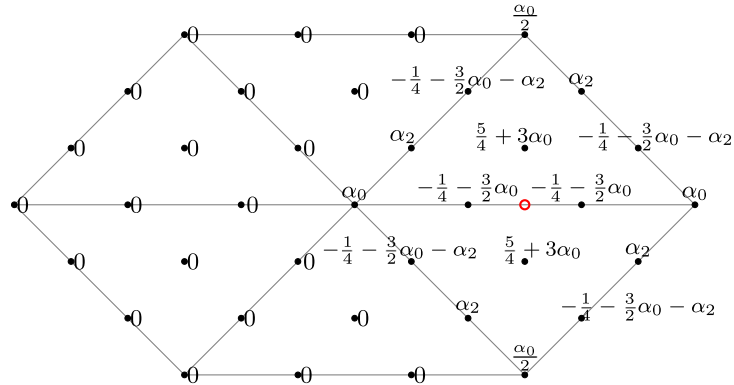

Fig. 6. Mask  $\alpha$  for the evaluation of the BB-coefficient associated with the point  $e_{i,j}^{1,1}$ . The coefficients of  $\alpha$  depend on two free parameters  $\alpha_0$  and  $\alpha_2$ .

In [27], the authors construct a quasi-interpolating spline, that we denote by  $Sf$ , providing specific masks  $\omega$ ,  $\alpha$  and  $\beta$ . The operator  $S : C(\mathbb{R}^2) \rightarrow \mathcal{S}_4^1(\Delta)$  associated with their quasi-interpolation scheme is exact on  $\mathbb{P}_3$ , its infinity norm is less than or equal to 10 and classical error estimates hold for enough regular functions (see e.g. [2,5]), i.e. for an arbitrary triangle  $T$  in  $\Delta$ , there exists an absolute constant  $K$  such that for every  $f \in C^{m+1}(\mathbb{R}^2)$ ,  $0 \leq m \leq 3$ ,

$$\|D^\gamma(f - Sf)\|_{\infty,T} \leq Kh^{m+1-|\gamma|} \|D^{m+1}f\|_{\infty,\Omega_T}, \tag{3.2}$$

for all  $0 \leq |\gamma| \leq m$ ,  $\gamma := (\gamma_1, \gamma_2)$ , with  $\Omega_T$  denoting the union of the triangles in  $\Delta$  having a non-empty intersection with  $T$ .

Here, we want to define and study a family of quasi-interpolating splines depending on free parameters. The scheme proposed in [27] belongs to this family and it is obtained by fixing the free parameters in a particular way.

We determine the BB-coefficients of the spline (and consequently the expression of the masks  $\omega$ ,  $\alpha$  and  $\beta$ ) by imposing the  $C^1$  continuity and the reproduction of  $\mathbb{P}_3$ , that is the space of polynomials of maximum degree that can be reproduced by a quasi-interpolating operator in  $\mathcal{S}_4^1(\Delta)$  (see e.g. [2,30]). Thus, the following constrains have to be satisfied

$$Q_{4,3}f \in C^1(\mathbb{R}^2), \quad \text{and} \quad Q_{4,3}f = f \text{ for all } f \in \mathbb{P}_3. \tag{3.3}$$

**Proposition 1.** *The problem (3.3) has infinitely many solutions depending on the fourteen parameters  $\alpha_0, \alpha_2, \beta_j, j \in \{1, 2, 3, 7, 8, 9, 10, 11, 12, 19, 20, 21\}$ . The values of the masks  $\alpha, \beta, \omega$  satisfy the conditions shown in Figs. 6–8, respectively and reported in the Appendix.*

**Proof.** As in [27], due to the symmetry of the partition, and since all the BB-coefficients are obtained by using a rotated version of the masks  $\omega, \alpha$  and  $\beta$  defining  $u_{i,j}^{1,1}, e_{i,j}^{1,1}$  and  $z_{i,j}^{1,1}$ , respectively, it is straightforward to verify that for the mask  $\alpha, \beta$  and  $\omega$  it holds  $c(v_{i,j}) + c(u_{i,j}^{1,1}) = c(u_{i,j}^{1,0}) + c(u_{i,j}^{0,1})$  and  $c(u_{i,j}^{1,1}) + c(e_{i,j}^{1,1}) = c(z_{i,j}^{1,1}) + c(z_{i,j}^{0,1})$ . These equalities guarantee the  $C^1$  class of  $Q_{4,3}f$ . To prove the exactness of  $Q_{4,3}$  on  $\mathbb{P}_3$  we show that it reproduces the Bernstein polynomials  $B_{i,j,k}^T, i + j + k = 3, T \in \Delta$ . As remarked in [27], it suffices to prove that  $Q_{4,3}(B_{3,0,0}^T) = B_{3,0,0}^T, Q_{4,3}(B_{2,1,0}^T) = B_{2,1,0}^T$  and  $Q_{4,3}(B_{1,1,1}^T) = B_{1,1,1}^T$ . We will prove the last one being  $T$  the triangle  $T_{i,j}$ . The proof for the triangle  $\tilde{T}_{i,j}$  is similar, as well as for the other Bernstein polynomials. We must determine the BB-coefficients of  $Q_{4,3}(B_{1,1,1}^T)$  on  $T_{i,j}$ . They are associated with the domain points  $v_{i,j}, u_{i,j}^{1,1}, u_{i,j}^{1,0}, u_{i,j}^{0,1}, e_{i,j}^{1,1}, z_{i,j}^{1,1}, e_{i,j}^{1,0}, u_{i+1,j+1}, z_{i+1,j+1}, z_{i+1,j}, u_{i+1,j}, v_{i+1,j+1}, u_{i+1,j+1}^{0,-1}, e_{i+1,j}^{0,1}, u_{i+1,j}^{-1,0}$  and  $v_{i+1,j}$  in  $T_{i,j}$ . To compute them, the values of  $B_{1,1,1} = B_{1,1,1}^{i,j}$  at the domain points in  $H_{i,j}$  are needed (see Fig. 3, as well as Fig. 5(left) for

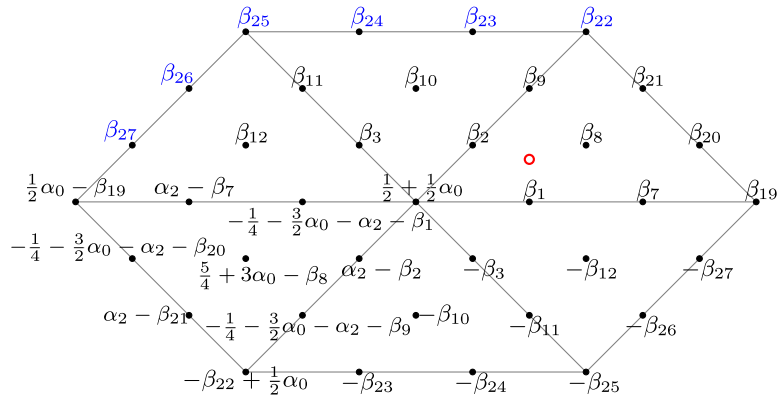

**Fig. 7.** Mask  $\beta$  for the evaluation of the BB-coefficient associated with the point  $z_{i,j}^{1,1}$ . The coefficients of  $\beta$  depend on the free parameters  $\alpha_0, \alpha_2$  and  $\beta_j, j \in \{1, 2, 3, 7, 8, 9, 10, 11, 12, 19, 20, 21\}$ . The expressions of the coefficients  $\beta_{22}, \beta_{23}, \beta_{24}, \beta_{25}, \beta_{26}, \beta_{27}$  (in blue) are reported in the Appendix. (For interpretation of the references to color in this figure legend, the reader is referred to the web version of this article.)

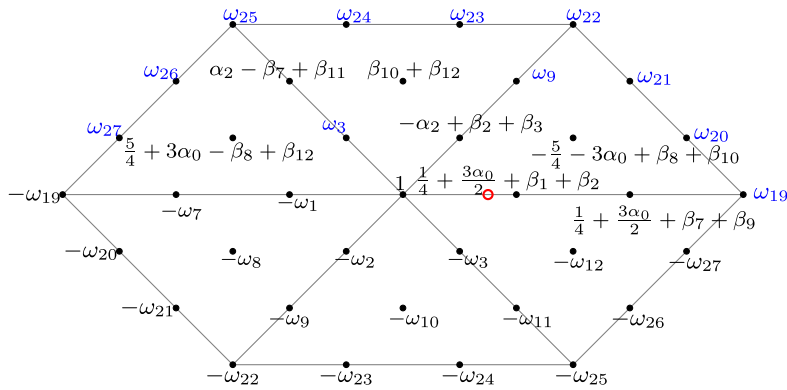

**Fig. 8.** Mask  $\omega$  for the evaluation of the BB-coefficient associated with the point  $u_{i,j}^{1,1}$ . The coefficients of  $\omega$  depend on the free parameters  $\alpha_0, \alpha_2$  and  $\beta_j, j \in \{1, 2, 3, 7, 8, 9, 10, 11, 12, 19, 20, 21\}$ . The expressions of the coefficients  $\omega_3, \omega_9, \omega_{19}, \omega_{20}, \omega_{21}, \omega_{22}, \omega_{23}, \omega_{24}, \omega_{25}, \omega_{26}, \omega_{27}$  (in blue) are reported in the Appendix. (For interpretation of the references to color in this figure legend, the reader is referred to the web version of this article.)

enumeration). They determine the list

$$\left( 0, 0, \frac{2}{9}, \frac{1}{3}, 0, \frac{4}{9}, \frac{1}{3}, 0, \frac{1}{9}, \frac{4}{9}, \frac{8}{9}, \frac{4}{9}, \frac{4}{9}, 0, \frac{5}{9}, \frac{20}{9}, \frac{16}{9}, \frac{4}{3}, \frac{2}{9}, 0, 0, 0, 0, 1, 2, 3, \frac{16}{9}, \frac{5}{9}, 0, \frac{2}{3}, \frac{8}{3}, 6, 5, 4, 3, \frac{8}{9}, \frac{1}{9} \right).$$

Thus, using the definitions in Section 3 for computing the BB-coefficients of the quasi-interpolating spline, the following expressions for  $Q_{4,3}(B_{1,1,1})$  on  $T_{i,j}$  result:

$$\begin{aligned} c(v_{i,j}) &= 0, \\ c(u_{i,j}^{1,1}) &= -\frac{2}{9}(3\omega_3 + 3\omega_6 - \omega_8 + 4\omega_{10} + 12\omega_{11} + 8\omega_{12} - 5\omega_{14} + 8\omega_{16} + 12\omega_{17} + 4\omega_{18} + 3\omega_{23} + 12\omega_{24} \\ &\quad + 27\omega_{25} + 24\omega_{26} + 15\omega_{27} - 12\omega_{29} - 12\omega_{30} + 15\omega_{32} + 24\omega_{33} + 27\omega_{34} + 12\omega_{35} + 3\omega_{36}), \\ c(u_{i,j}^{1,0}) &= -\frac{2}{9}(3\omega_2 + 3\omega_5 + 4\omega_8 + 12\omega_9 + 8\omega_{10} - 5\omega_{12} + 8\omega_{14} + 12\omega_{15} + 4\omega_{16} - \omega_{18} + 3\omega_{20} + 12\omega_{21} \\ &\quad + 27\omega_{22} + 24\omega_{23} + 15\omega_{24} - 12\omega_{26} - 12\omega_{27} + 15\omega_{29} + 24\omega_{30} + 27\omega_{31} + 12\omega_{32} + 3\omega_{33}), \\ c(e_{i,j}^{1,1}) &= -\frac{2}{9}(3\alpha_3 + 3\alpha_6 - \alpha_8 + 4\alpha_{10} + 12\alpha_{11} + 8\alpha_{12} - 5\alpha_{14} + 8\alpha_{16} + 12\alpha_{17} + 4\alpha_{18} + 3\alpha_{23} + 12\alpha_{24} \\ &\quad + 27\alpha_{25} + 24\alpha_{26} + 15\alpha_{27} - 12\alpha_{29} - 12\alpha_{30} + 15\alpha_{32} + 24\alpha_{33} + 27\alpha_{34} + 12\alpha_{35} + 3\alpha_{36}), \\ c(z_{i,j}^{1,1}) &= -\frac{2}{9}(3\beta_3 + 3\beta_6 - \beta_8 + 4\beta_{10} + 12\beta_{11} + 8\beta_{12} - 5\beta_{14} + 8\beta_{16} + 12\beta_{17} + 4\beta_{18} + 3\beta_{23} + 12\beta_{24} \\ &\quad + 27\beta_{25} + 24\beta_{26} + 15\beta_{27} - 12\beta_{29} - 12\beta_{30} + 15\beta_{32} + 24\beta_{33} + 27\beta_{34} + 12\beta_{35} + 3\beta_{36}), \end{aligned}$$

$$\begin{aligned}
 c(e_{i,j}^{1,0}) &= -\frac{2}{9} (3\alpha_2 + 3\alpha_5 + 4\alpha_8 + 12\alpha_9 + 8\alpha_{10} - 5\alpha_{12} + 8\alpha_{14} + 12\alpha_{15} + 4\alpha_{16} - \alpha_{18} + 3\alpha_{20} + 12\alpha_{21} \\
 &\quad + 27\alpha_{22} + 24\alpha_{23} + 15\alpha_{24} - 12\alpha_{26} - 12\alpha_{27} + 15\alpha_{29} + 24\alpha_{30} + 27\alpha_{31} + 12\alpha_{32} + 3\alpha_{33}), \\
 c(u_{i+1,j+1}^{-1,-1}) &= -\frac{2}{9} (3\omega_2 + 3\omega_5 + 4\omega_8 + 12\omega_9 + 8\omega_{10} - 5\omega_{12} + 8\omega_{14} + 12\omega_{15} + 4\omega_{16} - \omega_{18} + 3\omega_{20} + 12\omega_{21} \\
 &\quad + 27\omega_{22} + 24\omega_{23} + 15\omega_{24} - 12\omega_{26} - 12\omega_{27} + 15\omega_{29} + 24\omega_{30} + 27\omega_{31} + 12\omega_{32} + 3\omega_{33}), \\
 c(z_{i+1,j+1}^{0,-1}) &= -\frac{2}{9} (3\beta_3 + 3\beta_6 - \beta_8 + 4\beta_{10} + 12\beta_{11} + 8\beta_{12} - 5\beta_{14} + 8\beta_{16} + 12\beta_{17} + 4\beta_{18} + 3\beta_{23} + 12\beta_{24} \\
 &\quad + 27\beta_{25} + 24\beta_{26} + 15\beta_{27} - 12\beta_{29} - 12\beta_{30} + 15\beta_{32} + 24\beta_{33} + 27\beta_{34} + 12\beta_{35} + 3\beta_{36}), \\
 c(z_{i+1,j}^{-1,0}) &= -\frac{2}{9} (3\beta_3 + 3\beta_6 - \beta_8 + 4\beta_{10} + 12\beta_{11} + 8\beta_{12} - 5\beta_{14} + 8\beta_{16} + 12\beta_{17} + 4\beta_{18} + 3\beta_{23} + 12\beta_{24} \\
 &\quad + 27\beta_{25} + 24\beta_{26} + 15\beta_{27} - 12\beta_{29} - 12\beta_{30} + 15\beta_{32} + 24\beta_{33} + 27\beta_{34} + 12\beta_{35} + 3\beta_{36}), \\
 c(u_{i+1,j}^{-1,0}) &= -\frac{2}{9} (3\omega_3 + 3\omega_6 - \omega_8 + 4\omega_{10} + 12\omega_{11} + 8\omega_{12} - 5\omega_{14} + 8\omega_{16} + 12\omega_{17} + 4\omega_{18} + 3\omega_{23} + 12\omega_{24} \\
 &\quad + 27\omega_{25} + 24\omega_{26} + 15\omega_{27} - 12\omega_{29} - 12\omega_{30} + 15\omega_{32} + 24\omega_{33} + 27\omega_{34} + 12\omega_{35} + 3\omega_{36}), \\
 c(v_{i+1,j+1}) &= 0, \\
 c(u_{i+1,j+1}^{0,-1}) &= -\frac{2}{9} (3\omega_3 + 3\omega_6 - \omega_8 + 4\omega_{10} + 12\omega_{11} + 8\omega_{12} - 5\omega_{14} + 8\omega_{16} + 12\omega_{17} + 4\omega_{18} + 3\omega_{23} + 12\omega_{24} \\
 &\quad + 27\omega_{25} + 24\omega_{26} + 15\omega_{27} - 12\omega_{29} - 12\omega_{30} + 15\omega_{32} + 24\omega_{33} + 27\omega_{34} + 12\omega_{35} + 3\omega_{36}), \\
 c(e_{i+1,j}^{0,1}) &= -\frac{2}{9} (3\alpha_2 + 3\alpha_5 + 4\alpha_8 + 12\alpha_9 + 8\alpha_{10} - 5\alpha_{12} + 8\alpha_{14} + 12\alpha_{15} + 4\alpha_{16} - \alpha_{18} + 3\alpha_{20} + 12\alpha_{21} \\
 &\quad + 27\alpha_{22} + 24\alpha_{23} + 15\alpha_{24} - 12\alpha_{26} - 12\alpha_{27} + 15\alpha_{29} + 24\alpha_{30} + 27\alpha_{31} + 12\alpha_{32} + 3\alpha_{33}), \\
 c(u_{i+1,j}^{0,1}) &= -\frac{2}{9} (3\omega_2 + 3\omega_5 + 4\omega_8 + 12\omega_9 + 8\omega_{10} - 5\omega_{12} + 8\omega_{14} + 12\omega_{15} + 4\omega_{16} - \omega_{18} + 3\omega_{20} + 12\omega_{21} \\
 &\quad + 27\omega_{22} + 24\omega_{23} + 15\omega_{24} - 12\omega_{26} - 12\omega_{27} + 15\omega_{29} + 24\omega_{30} + 27\omega_{31} + 12\omega_{32} + 3\omega_{33}), \\
 c(v_{i+1,j}) &= 0.
 \end{aligned}$$

Direct substitution of masks  $\alpha, \beta, \omega$  reported in the and satisfying the conditions shown in Figs. 6–8 gives way to the values  $(0, 0, 0, 0, \frac{1}{2}, 0, 0, \frac{1}{2}, \frac{1}{2}, 0, 0, 0, 0, 0, 0)$ . They are the BB-coefficients of  $B_{1,1,1}$  on  $T_{i,j}$  as a quartic polynomial because  $B_{1,1,1} = \frac{3!}{1!1!1!} \lambda_1 \lambda_2 \lambda_3 (\lambda_1 + \lambda_2 + \lambda_3) = \frac{1}{2} (B_{2,1,1} + B_{1,2,1} + B_{1,1,2})$ . Therefore,  $Q_{4,3}$  reproduces  $B_{1,1,1}$ . □

Also for  $Q_{4,3}$  the estimates (3.2) hold.

Now, we propose different strategies to choose the free parameters.

The masks given in [27] correspond to the following ones:

$$\alpha_0 = \frac{1}{3}, \alpha_2 = -\frac{3}{8}, \beta_1 = \beta_2 = \beta_3 = \beta_{10} = \beta_{11} = \beta_{12} = 0, \beta_7 = \beta_9 = -\frac{9}{16}, \beta_8 = \frac{9}{4}, \beta_{19} = \frac{5}{24}, \beta_{20} = \beta_1 = -\frac{3}{8}.$$

A first immediate possibility consists in imposing all the free parameters equal to zero. Another possibility consists in minimizing the maximum of the quasi-interpolation errors  $\|Q_{4,3}m_\gamma - m_\gamma\|_\infty$  for the quartic monomials  $(m_\gamma(x, y) = x^\gamma y^{\gamma_2}, |\gamma| = 4)$ , subject to the reproduction of the cubic polynomials. After some computations, it can be proven that the objective function depends only on  $\alpha_0$  and  $\alpha_2$ . The minimum is attained uniquely when  $\alpha_0 = \frac{10}{21}$  and  $\alpha_2 = -\frac{27}{56}$ . Once again,  $\beta_1, \beta_2, \beta_3, \beta_7, \beta_8, \beta_9, \beta_{10}, \beta_{11}, \beta_{12}, \beta_{19}, \beta_{20}, \beta_{21}$  are free parameters. In order to find appropriate values for them, the maximum of the quasi-interpolation errors associated with the quintic monomials can be minimized. The constrained optimization problem is equivalent to a unconstrained problem that can be expressed into the form  $\max_{1 \leq j \leq p} |\sum_{i=1}^m z_i b_{ij} - c_j|$ . It is transformed into a linear programming problem whose solution is attained only at

$$\begin{aligned}
 \beta_1 = \beta_2 = \beta_3 = \beta_7 = \beta_9 = \beta_{11} = 0, \beta_8 &= \frac{613}{448}, \beta_{10} = -\frac{321}{4480}, \beta_{12} = \frac{653}{4480}, \\
 \beta_{19} = \frac{1803}{11200}, \beta_{20} = -\frac{5021}{14000}, \beta_{21} &= -\frac{7683}{28000}.
 \end{aligned} \tag{3.4}$$

Since the Bernstein polynomials form a partition of unity, we have that

$$|Q_{4,3}f| \leq \max \{ \|\alpha\|_1, \|\beta\|_1, \|\omega\|_1 \} = \max \left\{ \sum_{k=0}^{36} |\alpha_k|, \sum_{k=0}^{36} |\beta_k|, \sum_{k=0}^{36} |\omega_k| \right\},$$

for a function  $f$  with  $\|f\|_\infty = 1$ , so that  $\|Q_{4,3}\|_\infty \leq \max \{ \|\alpha\|_1, \|\beta\|_1, \|\omega\|_1 \}$ . For this choice of parameters, we obtain that the infinity norm of  $Q_{4,3}$  is bounded by  $\frac{47697}{2800} \approx 17.03$ .

Another criterion for the selection of the free parameters could be the minimization of the operator norm.

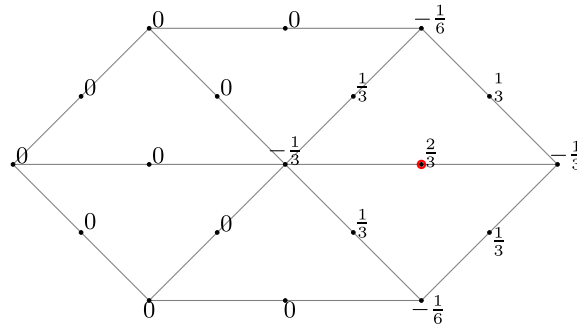

Fig. 9. Mask  $\alpha$  for the evaluation of the BB-coefficient associated with the point  $e_{ij}^{1,1}$ .

### 4. $C^1$ quartic quasi-interpolating splines based on $\mathcal{D}_2$ point values

The degree of the splines and the required exactness motivate the use of the lattices  $\mathcal{D}_4$  and  $\mathcal{D}_3$  in [27] to define the  $C^1$ -quartic quasi-interpolating spline on  $\Delta$ . The previous study shows that there are infinitely many solutions to the considered problem, and therefore there is a reasonable prospect that there are masks with fewer points providing operators that behave in the same way.

Now, we use the same logical scheme of the previous section to construct a quasi-interpolating spline  $Q_{4,2}f$  based on the values  $f(v)$ ,  $v \in \mathcal{D}_2$  and therefore using fewer points with respect to  $Q_{4,3}f$ .

Taking into account the symmetry of  $\Delta$ , also in this case it is sufficient to determine the setting of the BB-coefficients corresponding to one of the domain points denoted by the letters  $v, u, e$  and  $z$  in  $\mathcal{D}_4$ , in order to compute (3.1). The other ones can be obtained by translation and/or rotation.

Let  $c(v_{i,j}) := f(v_{i,j})$ . The BB-coefficients corresponding to the domain points denoted by the letters  $u, e$  and  $z$ , are expressed as linear combinations of the values of  $f$  at the 19 domain points of  $\mathcal{D}_2$  lying in  $H_{i,j}$  (see Fig. 4).

Let  $f_{i,j}(\mathcal{D}_2) \in \mathbb{R}^{19}$  be the vector of the values of  $f$  at the 19 domain points of  $\mathcal{D}_2$  lying in  $H_{i,j}$  and let  $\alpha \in \mathbb{R}^{19}$ ,  $\beta \in \mathbb{R}^{19}$  and  $\omega \in \mathbb{R}^{19}$  be the three masks, enumerated as in Fig. 5(right). Therefore, we write  $c(e_{ij}^{1,1}) = f_{i,j}(\mathcal{D}_2) \cdot \alpha$ ,  $c(z_{ij}^{1,1}) = f_{i,j}(\mathcal{D}_2) \cdot \beta$ , and  $c(u_{ij}^{1,1}) = f_{i,j}(\mathcal{D}_2) \cdot \omega$ .

By imposing the same constrains of (3.3), we have the problem

$$Q_{4,2}f \in C^1(\mathbb{R}^2) \quad \text{and} \quad Q_{4,2}f = f \text{ for all } f \in \mathbb{P}_3, \tag{4.1}$$

and, by using a symbolic computation software, the following result is established.

**Proposition 2.** *The problem (4.1) has infinitely many solutions depending on the three parameters  $\beta_1, \beta_2, \beta_3$ . The values of the mask  $\alpha$  (see Fig. 9) are fixed, with  $\alpha_j = 0, j \in \{3, 4, 5, 10, 11, 12, 13, 14, 15, 16\}$ , and*

$$\alpha_0 = \alpha_7 = -\frac{1}{3}, \alpha_1 = \frac{2}{3}, \alpha_2 = \alpha_6 = \alpha_8 = \alpha_{18} = \frac{1}{3}, \alpha_9 = \alpha_{17} = -\frac{1}{6}.$$

The values of the masks  $\beta$  and  $\omega$  satisfy the following conditions (see Figs. 10, 11):

$$\begin{aligned} \beta_0 &= \frac{1}{3}, \beta_4 = \frac{1}{3} - \beta_1, \beta_5 = \frac{1}{3} - \beta_2, \beta_6 = -\beta_3, \beta_7 = -\frac{5}{8} + \frac{5}{8}\beta_1 + \frac{3}{8}\beta_2 - \frac{3}{8}\beta_3, \beta_8 = \frac{7}{6} - \beta_1 - \beta_2, \\ \beta_9 &= -\frac{5}{8} + \frac{3}{8}\beta_1 + \frac{5}{8}\beta_2 + \frac{3}{8}\beta_3, \beta_{10} = \frac{1}{2} - \beta_2 - \beta_3, \beta_{11} = -\frac{3}{8}\beta_1 + \frac{3}{8}\beta_2 + \frac{5}{8}\beta_3, \beta_{12} = -\frac{1}{2} + \beta_1 - \beta_3, \\ \beta_{13} &= \frac{11}{24} - \frac{5}{8}\beta_1 - \frac{3}{8}\beta_2 + \frac{3}{8}\beta_3, \beta_{14} = -\frac{5}{6} + \beta_1 + \beta_2, \beta_{15} = \frac{11}{24} - \frac{3}{8}\beta_1 - \frac{5}{8}\beta_2 - \frac{3}{8}\beta_3, \beta_{16} = -\frac{1}{2} + \beta_2 + \beta_3, \\ \beta_{17} &= \frac{3}{8}\beta_1 - \frac{3}{8}\beta_2 - \frac{5}{8}\beta_3, \beta_{18} = \frac{1}{2} - \beta_1 + \beta_3, \\ \omega_0 &= 1, \omega_1 = -\frac{2}{3} + \beta_1 + \beta_2, \omega_2 = -\frac{1}{3} + \beta_2 + \beta_3, \omega_3 = \frac{1}{3} - \beta_1 + \beta_3, \omega_4 = \frac{2}{3} - \beta_1 - \beta_2, \omega_5 = \frac{1}{3} - \beta_2 - \beta_3, \\ \omega_6 &= -\frac{1}{3} + \beta_1 - \beta_3, \omega_7 = -\frac{11}{12} + \beta_1 + \beta_2, \omega_8 = \frac{4}{3} - \beta_1 - 2\beta_2 - \beta_3, \omega_9 = -\frac{11}{24} + \beta_2 + \beta_3, \\ \omega_{10} &= \beta_1 - \beta_2 - 2\beta_3, \omega_{11} = \frac{11}{24} - \beta_1 + \beta_3, \omega_{12} = -\frac{4}{3} + 2\beta_1 + \beta_2 - \beta_3, \omega_{13} = \frac{11}{12} - \beta_1 - \beta_2, \\ \omega_{14} &= -\frac{4}{3} + \beta_1 + 2\beta_2 + \beta_3, \omega_{15} = \frac{11}{24} - \beta_2 - \beta_3, \omega_{16} = -\beta_1 + \beta_2 + 2\beta_3, \omega_{17} = -\frac{11}{24} + \beta_1 - \beta_3, \\ \omega_{18} &= \frac{4}{3} - 2\beta_1 - \beta_2 + \beta_3. \end{aligned}$$

Notice that for all  $\beta_1, \beta_2$  and  $\beta_3$  the error estimates (3.2) hold for the corresponding operator  $Q_{4,2}$ .

Now, we want to propose different strategies to choose the free parameters.

A first possibility consists in imposing all the free parameters equal to zero. Instead, if we require  $\beta_1 = \beta_2$  and  $\beta_3 = 0$ , we obtain masks  $\beta$  and  $\omega$  with nice symmetry properties, depending on the parameter  $\beta_1$ . Then we choose the parameter  $\beta_1$  by



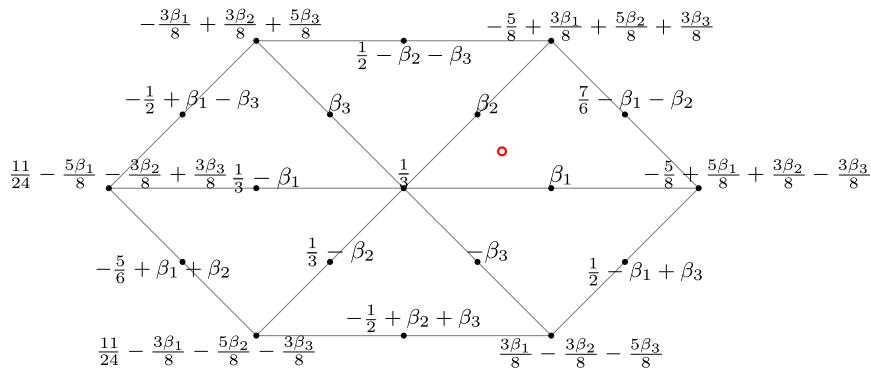

Fig. 10. Mask  $\beta$  for the evaluation of the BB-coefficient associated with the point  $z_{ij}^{1,1}$ .

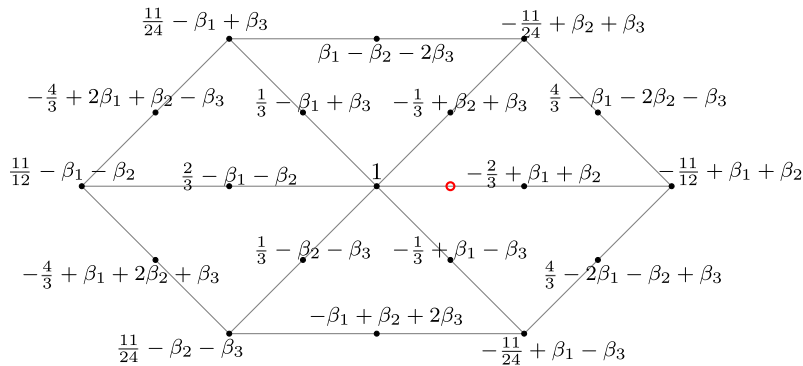

Fig. 11. Mask  $\omega$  for the evaluation of the BB-coefficient associated with the point  $u_{ij}^{1,1}$ .

minimizing an upper bound for the infinity norm of  $Q_{4,2}$ . Indeed, since  $\|Q_{4,2}\|_\infty \leq \max \{ \|\alpha\|_1, \|\beta\|_1, \|\omega\|_1 \}$  and  $\|\alpha\|_1 = 3$ , by using a symbolic computation software we find that the infinity norm of  $Q_{4,2}$  is equal to 3 for  $\beta_1 \in \left[ \frac{13}{36}, \frac{41}{84} \right]$ .

### 5. Numerical results

In this section, we show the results of some numerical tests, developed in the Matlab environment, for several operators on Franke’s function

$$f_1(x) = 0.75e^{\left( -\frac{(9x_1-2)^2}{4} - \frac{(9x_2-2)^2}{4} \right)} + 0.75e^{\left( -\frac{(9x_1+1)^2}{49} - \frac{9x_2+1}{10} \right)} + 0.5e^{\left( -\frac{(9x_1-7)^2}{4} - \frac{(9x_2-3)^2}{4} \right)} - 0.2e^{-(9x_1-4)^2 - (9x_2-7)^2},$$

and the highly oscillating test function  $f_2(x) = 0.1 \left( 1 + \cos \left( 12\pi \cos \left( \pi \sqrt{x_1^2 + x_2^2} \right) \right) \right)$ , both defined on the unit square  $[0, 1]^2$  and compare them with the ones provided by the operator  $S$  defined in [27].

In general, for a step length  $h$ , the maximal error (ME) for a given function  $f$  and a quasi-interpolation operator  $Q$  is estimated as the value  $ME_h$  given by maximum of the quasi-interpolation error  $|f - Qf|$  on a finite subset  $G = \{ (g_{1,i}, g_{2,j}) : (i, j) \in J \}$  of points lying in the unit square, and the root mean square error (RMSE) as  $RMSE_h := \sqrt{\frac{\sum_{(i,j) \in J} (f(g_{1,i}, g_{2,j}) - Qf(g_{1,i}, g_{2,j}))^2}{\text{card} J}}$ , with  $\text{card} J$  standing for the cardinality of  $J$ .

In order to evaluate these values we have sampled the splines on 300 points in each triangle of  $\Delta$ , for any considered value of  $h$ . The evaluation of the quasi-interpolating splines is carried out by the de Casteljau’s algorithm [5, p. 25].

The numerical convergence orders are computed by the formula  $NCO := \log_2 \frac{ME_h}{ME_{h/2}}$ .

We have omitted any reference to  $f$  and  $Q$  in denoting these quantities.

For the more difficult function  $f_2$ , we started the computations by using a larger set of data points, i.e. by considering an initial value of  $h$  smaller than the one used for the test function  $f_1$ .

Concerning the quasi-interpolating splines based on the points of  $\mathcal{D}_3$ , we have obtained the results given in Tables 1–3. In particular, Table 1 contains the maximal and root mean square errors and the numerical convergence orders provided by

**Table 1**

Numerical results given by the spline based on the points of  $\mathcal{D}_3$  whose masks are obtained by considering all the 14 free parameters equal to zero in Proposition 1.

$h$	Test function $f_1$			Test function $f_2$		
	$ME_h$	$NCO$	$RMSE_h$	$ME_h$	$NCO$	$RMSE_h$
1/4	$4.95 \times 10^{-1}$	–	$1.66 \times 10^{-1}$			
1/8	$1.93 \times 10^{-1}$	1.36	$3.34 \times 10^{-2}$			
1/16	$1.37 \times 10^{-1}$	3.82	$2.22 \times 10^{-3}$	1.81	–	$4.06 \times 10^{-1}$
1/32	$6.26 \times 10^{-4}$	4.44	$8.19 \times 10^{-5}$	1.23	0.51	$1.81 \times 10^{-1}$
1/64	$2.70 \times 10^{-5}$	4.53	$2.91 \times 10^{-6}$	$1.06 \times 10^{-1}$	3.58	$1.41 \times 10^{-2}$
1/128	$1.33 \times 10^{-6}$	4.34	$1.25 \times 10^{-7}$	$3.96 \times 10^{-3}$	4.74	$4.82 \times 10^{-4}$
1/256	$7.69 \times 10^{-8}$	4.12	$6.63 \times 10^{-9}$	$1.34 \times 10^{-4}$	4.89	$1.70 \times 10^{-5}$
1/512	$4.69 \times 10^{-9}$	4.03	$3.94 \times 10^{-10}$	$5.64 \times 10^{-6}$	4.57	$7.52 \times 10^{-7}$

**Table 2**

Numerical results given by the spline based on the points of  $\mathcal{D}_3$  whose masks are obtained by computing the free parameters in Proposition 1 minimizing the error for quartic and quintic monomials.

$h$	Test function $f_1$			Test function $f_2$		
	$ME_h$	$NCO$	$RMSE_h$	$ME_h$	$NCO$	$RMSE_h$
1/4	$1.09 \times 10^{-1}$	–	$2.75 \times 10^{-2}$			
1/8	$2.06 \times 10^{-2}$	2.41	$3.80 \times 10^{-3}$			
1/16	$3.57 \times 10^{-3}$	2.53	$3.46 \times 10^{-4}$	$4.13 \times 10^{-1}$	–	$8.60 \times 10^{-2}$
1/32	$2.37 \times 10^{-4}$	3.91	$1.85 \times 10^{-5}$	$1.57 \times 10^{-1}$	1.40	$2.19 \times 10^{-2}$
1/64	$1.17 \times 10^{-5}$	4.34	$9.57 \times 10^{-7}$	$1.63 \times 10^{-2}$	3.27	$2.49 \times 10^{-3}$
1/128	$6.74 \times 10^{-7}$	4.12	$5.55 \times 10^{-8}$	$9.43 \times 10^{-4}$	4.11	$1.30 \times 10^{-4}$
1/256	$4.08 \times 10^{-8}$	4.05	$3.40 \times 10^{-9}$	$4.69 \times 10^{-5}$	4.33	$6.35 \times 10^{-6}$
1/512	$2.53 \times 10^{-9}$	4.01	$2.11 \times 10^{-10}$	$3.01 \times 10^{-6}$	3.96	$3.57 \times 10^{-7}$

**Table 3**

Numerical results given by the spline proposed in [27].

$h$	Test function $f_1$			Test function $f_2$		
	$ME_h$	$NCO$	$RMSE_h$	$ME_h$	$NCO$	$RMSE_h$
1/4	$7.27 \times 10^{-2}$	–	$1.78 \times 10^{-2}$			
1/8	$1.56 \times 10^{-2}$	2.22	$1.76 \times 10^{-3}$			
1/16	$1.28 \times 10^{-3}$	3.61	$1.37 \times 10^{-4}$	$4.02 \times 10^{-1}$	–	$8.54 \times 10^{-2}$
1/32	$1.02 \times 10^{-4}$	3.64	$1.14 \times 10^{-5}$	$8.86 \times 10^{-2}$	2.18	$1.06 \times 10^{-2}$
1/64	$1.06 \times 10^{-5}$	3.27	$8.37 \times 10^{-7}$	$7.66 \times 10^{-3}$	3.53	$8.05 \times 10^{-4}$
1/128	$7.70 \times 10^{-7}$	3.79	$5.54 \times 10^{-8}$	$4.51 \times 10^{-4}$	4.08	$6.74 \times 10^{-5}$
1/256	$4.97 \times 10^{-8}$	3.95	$3.52 \times 10^{-9}$	$3.73 \times 10^{-5}$	3.60	$5.20 \times 10^{-6}$
1/512	$3.13 \times 10^{-9}$	3.99	$2.21 \times 10^{-10}$	$2.79 \times 10^{-6}$	3.74	$3.47 \times 10^{-7}$

**Table 4**

Numerical results given by the spline based on the points of  $\mathcal{D}_2$  whose masks are obtained by considering all the 3 free parameters equal to zero in Proposition 2.

$h$	Test function $f_1$			Test function $f_2$		
	$ME_h$	$NCO$	$RMSE_h$	$ME_h$	$NCO$	$RMSE_h$
1/4	$2.65 \times 10^{-1}$	–	$9.56 \times 10^{-2}$			
1/8	$9.33 \times 10^{-2}$	1.51	$2.08 \times 10^{-2}$			
1/16	$1.79 \times 10^{-2}$	2.38	$1.80 \times 10^{-3}$			
1/32	$9.52 \times 10^{-4}$	4.23	$8.54 \times 10^{-5}$			
1/64	$3.71 \times 10^{-5}$	4.68	$3.51 \times 10^{-6}$	$1.25 \times 10^{-1}$	–	$1.28 \times 10^{-2}$
1/128	$1.93 \times 10^{-6}$	4.26	$1.76 \times 10^{-7}$	$5.90 \times 10^{-3}$	4.40	$5.84 \times 10^{-4}$
1/256	$1.15 \times 10^{-7}$	4.07	$1.03 \times 10^{-8}$	$1.94 \times 10^{-4}$	4.93	$2.30 \times 10^{-5}$
1/512	$7.08 \times 10^{-9}$	4.02	$6.30 \times 10^{-10}$	$8.42 \times 10^{-6}$	4.52	$1.12 \times 10^{-6}$

the spline in Proposition 1 with all free parameters equal to zero. The results for the quasi-interpolation scheme with masks obtained by minimizing the error for quartic and quintic monomials, provided by the values  $\alpha_0 = \frac{10}{21}, \alpha_2 = -\frac{27}{56}$  and, are shown in Table 2. Finally, Table 3 shows the results for the quasi-interpolating splines  $Sf_1$  and  $Sf_2$  defined in [27]. The results confirm the theoretical value for the convergence order.

Concerning the quasi-interpolating splines based on the points of  $\mathcal{D}_2$ , we have obtained the results given in Tables 4 and 5. In particular, Table 4 contains the maximal and root mean errors and the numerical convergence orders provided by the spline in Proposition 2 with all the three free parameters equal to zero. The results for the quasi-interpolation scheme with masks obtained by imposing symmetry and choosing  $\beta_1 = \frac{2}{3}$ , are shown in Table 5. The results confirm the theoretical value for the convergence order.

**Table 5**

Numerical results given by the spline based on the points of  $\mathcal{D}_2$  whose masks are obtained by computing the free parameters in Proposition 2 imposing symmetry and choosing  $\beta_1 = \frac{2}{5}$ .

$h$	Test function $f_1$			Test function $f_2$		
	$ME_h$	NCO	$RMSE_h$	$ME_h$	NCO	$RMSE_h$
1/4	$1.69 \times 10^{-1}$	–	$4.25 \times 10^{-2}$			
1/8	$4.48 \times 10^{-2}$	1.92	$8.06 \times 10^{-3}$			
1/16	$7.90 \times 10^{-3}$	2.50	$7.40 \times 10^{-4}$			
1/32	$4.92 \times 10^{-4}$	4.01	$4.52 \times 10^{-5}$			
1/64	$2.96 \times 10^{-5}$	4.05	$2.64 \times 10^{-6}$	$4.04 \times 10^{-2}$	–	$4.83 \times 10^{-3}$
1/128	$1.82 \times 10^{-6}$	4.02	$1.61 \times 10^{-7}$	$2.39 \times 10^{-3}$	4.08	$2.91 \times 10^{-4}$
1/256	$1.13 \times 10^{-7}$	4.01	$1.00 \times 10^{-8}$	$1.25 \times 10^{-4}$	4.26	$1.67 \times 10^{-5}$
1/512	$7.05 \times 10^{-9}$	4.00	$6.26 \times 10^{-10}$	$7.31 \times 10^{-6}$	4.10	$1.01 \times 10^{-6}$

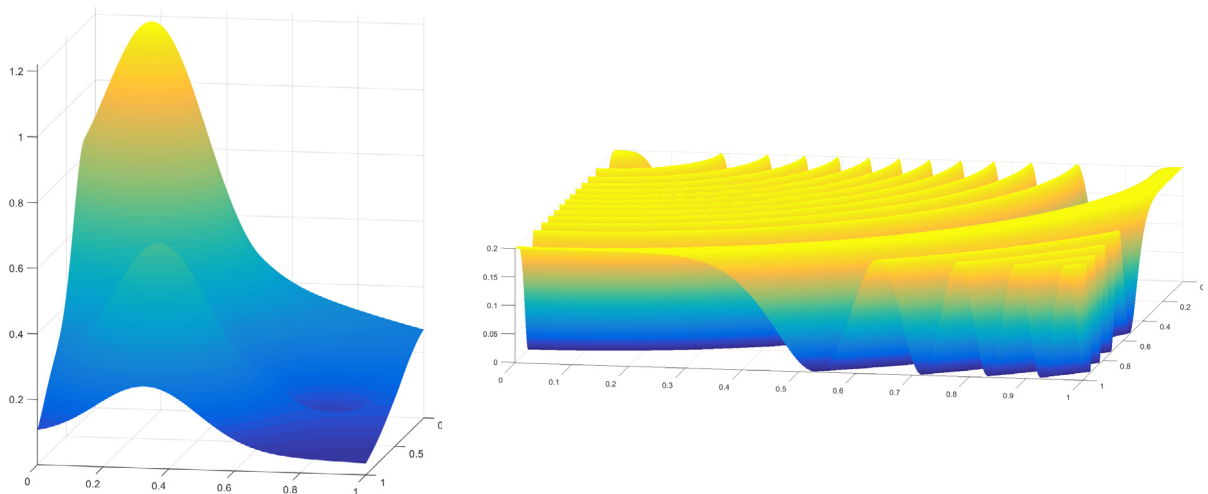

**Fig. 12.** The quartic  $C^1$  splines  $Q_{4,3}f_1$  with  $h = 1/64$  (left) and  $Q_{4,3}f_2$  (right) with  $h = 1/128$ , whose masks are obtained by computing the free parameters in Proposition 1 minimizing the error for quartic and quintic monomials.

Moreover, the approach proposed in the paper produces visually pleasant surfaces, as shown in Figs. 12 and 13.

Finally, we remark that the two families of quasi-interpolating splines  $Q_{4,3}f$  and  $Q_{4,2}f$ , based on the points of  $\mathcal{D}_3$  and  $\mathcal{D}_2$ , respectively, produce similar results. However, the number of evaluation points is halved in case of  $Q_{4,2}f$  and therefore the computational cost is reduced.

We remark that, in order to compute the BB-coefficients related to triangles having a non interior vertex, we have extended the triangulation, to be able to compute the corresponding masks.

### 6. Conclusions

We have analyzed the construction of  $C^1$  quartic quasi-interpolants defined on a type-1 triangulation without imposing a structure based on the translation of one or more compactly supported functions. Instead, the quasi-interpolating splines are determined by setting their BB-coefficients to appropriate combinations of the given data only using values of the function to be approximated. The associated operator reproduces cubic polynomials.

We have considered two different sets of evaluation points. In the first case, it has been proved that this problem has a general solution depending of fourteen parameters. The scheme proposed in [27] is a particular case that provides a quasi-interpolation operator with uniform norm equal to 10. We have also constructed an operator that minimizes the maximum of the quasi-interpolation errors for quartic and quintic monomials and it behaves like the operator in [27]. In the second case, the number of points involved in the computation of the BB-coefficients is smaller. The masks are composed of 19 values instead of 37. The general solution corresponds to a mask without free parameters and two masks depending on only three parameters. A specific choice yields a scheme depending on a parameter and having nice symmetries. The free parameter can be chosen to produce operators with infinity norm equal to 3. The main contribution in this case is that the computational cost has been halved. Moreover, a better result with respect to the uniform norm has been obtained.

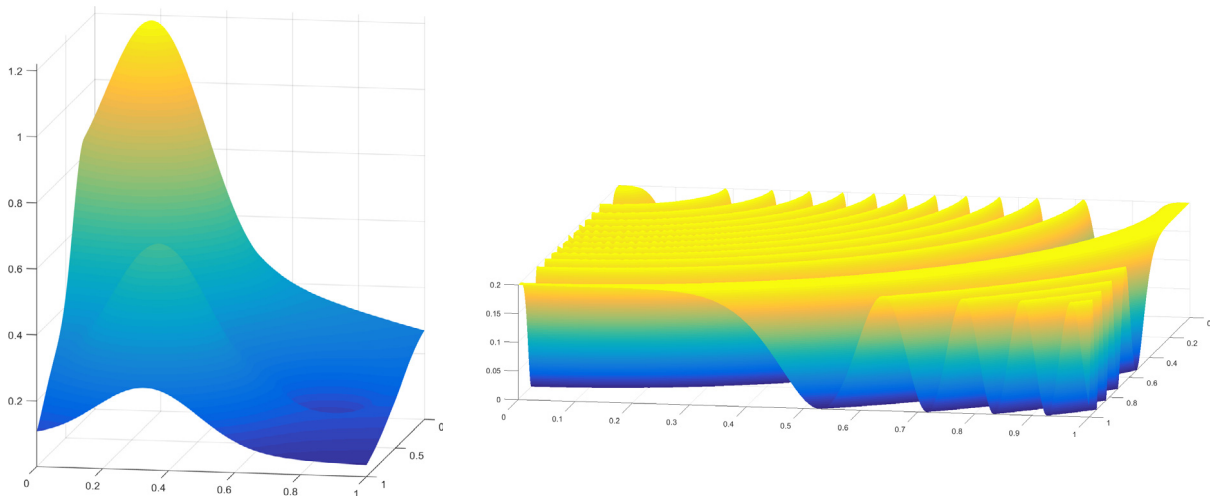

**Fig. 13.** The quartic  $C^1$  splines  $Q_{4,2}f_1$  with  $h = 1/64$  (left) and  $Q_{4,2}f_2$  with  $h = 1/128$  (right), whose masks are obtained by computing the free parameters in Proposition 2 imposing symmetry and choosing  $\beta_1 = \frac{2}{5}$ .

**Acknowledgments**

This work was initiated during the visiting on 2017, March of the first and third authors to the Department of Mathematics of the University of Torino, and partially realized during the visiting of the fourth author to the Department of Applied Mathematics of the University of Granada on 2017, November. They thank the financial support of both institutions and the Gruppo Nazionale per il Calcolo Scientifico (GNCS) - INDAM. Finally, the authors wish to thank the anonymous referees for their comments which helped them to improve the original manuscript.

**Appendix**

The values of the masks  $\alpha, \beta, \omega$  in Proposition 1, solution of the problem (3.3), satisfy the following conditions:

• mask  $\alpha$ :

$$\alpha_1 = \alpha_7 = -\frac{1}{4} - \frac{3}{2}\alpha_0, \alpha_6 = \alpha_9 = \alpha_{20} = \alpha_{35} = -\frac{1}{4} - \frac{3}{2}\alpha_0 - \alpha_2, \alpha_8 = \alpha_{18} = \frac{5}{4} + 3\alpha_0, \alpha_{17} = \alpha_{21} = \alpha_{36} = \alpha_2, \alpha_{19} = \alpha_0, \alpha_{22} = \alpha_{34} = \frac{1}{2}\alpha_0, \alpha_j = 0, j \in \{3, 4, 5, 10, 11, 12, 13, 14, 15, 16, 23, 24, 25, 26, 27, 28, 29, 30, 31, 32, 33\},$$

• mask  $\beta$

$$\begin{aligned} \beta_0 &= \frac{1}{2} + \frac{1}{2}\alpha_0, \beta_4 = -\frac{1}{4} - \frac{3}{2}\alpha_0 - \alpha_2 - \beta_1, \beta_5 = \alpha_2 - \beta_2, \beta_6 = -\beta_3, \beta_{13} = \alpha_2 - \beta_7, \beta_{14} = \frac{5}{4} + 3\alpha_0 - \beta_8, \\ \beta_{15} &= -\frac{1}{4} - \frac{3}{2}\alpha_0 - \alpha_2 - \beta_9, \beta_{16} = -\beta_{10}, \beta_{17} = -\beta_{11}, \beta_{18} = -\beta_{12}, \\ \beta_{22} &= -\frac{35}{24} + \beta_1 + \beta_2 + \beta_7 + \frac{4}{3}\beta_8 + \beta_9 + \frac{2}{3}\beta_{10} - \frac{2}{3}\beta_{12} - \beta_{19}, \\ \beta_{23} &= \frac{865}{192} - \frac{1}{16}\alpha_0 + \frac{1}{12}\alpha_2 - \frac{13}{4}\beta_1 - 3\beta_2 + \frac{1}{3}\beta_3 - \frac{7}{2}\beta_7 - \frac{14}{3}\beta_8 - \frac{15}{4}\beta_9 - \frac{11}{6}\beta_{10} \\ &\quad + \frac{5}{12}\beta_{11} + \frac{7}{3}\beta_{12} + \frac{9}{4}\beta_{19} - \frac{5}{3}\beta_{20} - \frac{7}{3}\beta_{21}, \\ \beta_{24} &= -\frac{253}{60} + \frac{1}{5}\alpha_0 - \frac{1}{15}\alpha_2 + \frac{17}{5}\beta_1 + \frac{12}{5}\beta_2 - \frac{16}{15}\beta_3 + \frac{19}{5}\beta_7 + \frac{68}{15}\beta_8 + 3\beta_9 + \frac{2}{3}\beta_{10} \\ &\quad - \frac{4}{3}\beta_{11} - \frac{43}{15}\beta_{12} - \frac{9}{5}\beta_{19} + \frac{7}{3}\beta_{20} + \frac{8}{3}\beta_{21}, \\ \beta_{25} &= \frac{35}{48} - \beta_1 + \beta_3 - \beta_7 - \frac{2}{3}\beta_8 + \frac{2}{3}\beta_{10} + \beta_{11} + \frac{4}{3}\beta_{12} + \beta_{19}, \\ \beta_{26} &= \frac{63}{40} - \frac{3}{10}\alpha_0 - \frac{1}{15}\alpha_2 - \frac{3}{5}\beta_1 - \frac{8}{5}\beta_2 - \frac{16}{15}\beta_3 - \frac{6}{5}\beta_7 - \frac{32}{15}\beta_8 - 2\beta_9 - \frac{5}{3}\beta_{10} - \frac{4}{3}\beta_{11} \\ &\quad - \frac{8}{15}\beta_{12} - \frac{9}{5}\beta_{19} - \frac{8}{3}\beta_{20} - \frac{7}{3}\beta_{21}, \end{aligned}$$

$$\begin{aligned}\beta_{27} &= -\frac{77}{64} + \frac{3}{16}\alpha_0 + \frac{1}{12}\alpha_2 + \frac{3}{4}\beta_1 + \beta_2 + \frac{1}{3}\beta_3 + \frac{3}{2}\beta_7 + \frac{5}{3}\beta_8 + \frac{5}{4}\beta_9 + \frac{5}{6}\beta_{10} \\ &\quad + \frac{5}{12}\beta_{11} - \frac{1}{3}\beta_{12} + \frac{9}{4}\beta_{19} + \frac{7}{3}\beta_{20} + \frac{5}{3}\beta_{21}, \\ \beta_{28} &= \frac{1}{2}\alpha_0 - \beta_{19}, \quad \beta_{29} = -\frac{1}{4} - \frac{3}{2}\alpha_0 - \alpha_2 - \beta_{20}, \quad \beta_{30} = \alpha_2 - \beta_{21}, \\ \beta_{31} &= -\beta_{22} + \frac{1}{2}\alpha_0, \quad \beta_{32} = -\beta_{23}, \quad \beta_{33} = -\beta_{24}, \quad \beta_{34} = -\beta_{25}, \quad \beta_{35} = -\beta_{26}, \quad \beta_{36} = -\beta_{27}.\end{aligned}$$

• mask  $\omega$

$$\begin{aligned}\omega_0 &= 1, \quad \omega_1 = \frac{1}{4} + \frac{3}{2}\alpha_0 + \beta_1 + \beta_2, \quad \omega_2 = -\alpha_2 + \beta_2 + \beta_3, \quad \omega_3 = -\frac{1}{4} - \frac{3}{2}\alpha_0 - \alpha_2 - \beta_1 + \beta_3, \quad \omega_4 = -\omega_1, \quad \omega_5 = -\omega_2, \\ \omega_6 &= -\omega_3, \quad \omega_7 = \frac{1}{4} + \frac{3}{2}\alpha_0 + \beta_7 + \beta_9, \quad \omega_8 = -\frac{5}{4} - 3\alpha_0 + \beta_8 + \beta_{10}, \quad \omega_9 = \frac{1}{4} + \frac{3}{2}\alpha_0 + \alpha_2 + \beta_9 + \beta_{11}, \quad \omega_{10} = \beta_{10} + \beta_{12}, \\ \omega_{11} &= \alpha_2 - \beta_7 + \beta_{11}, \quad \omega_{12} = \frac{5}{4} + 3\alpha_0 - \beta_8 + \beta_{12}, \quad \omega_{13} = -\omega_7, \quad \omega_{14} = -\omega_8, \quad \omega_{15} = -\omega_9, \quad \omega_{16} = -\omega_{10}, \quad \omega_{17} = -\omega_{11}, \\ \omega_{18} &= -\omega_{12}, \quad \omega_{19} = -\frac{35}{24} - \alpha_0 + \beta_1 + \beta_2 + \beta_7 + \frac{4}{3}\beta_8 + \beta_9 + \frac{2}{3}\beta_{10} - \frac{2}{3}\beta_{12}, \\ \omega_{20} &= \frac{913}{192} + \frac{23}{16}\alpha_0 + \frac{13}{12}\alpha_2 - \frac{13}{4}\beta_1 - 3\beta_2 + \frac{1}{3}\beta_3 - \frac{7}{2}\beta_7 - \frac{14}{3}\beta_8 - \frac{15}{4}\beta_9 - \frac{11}{6}\beta_{10} \\ &\quad + \frac{5}{12}\beta_{11} + \frac{7}{3}\beta_{12} + \frac{9}{4}\beta_{19} - \frac{2}{3}\beta_{20} - \frac{7}{3}\beta_{21}, \\ \omega_{21} &= -\frac{253}{60} + \frac{1}{5}\alpha_0 - \frac{16}{15}\alpha_2 + \frac{17}{5}\beta_1 + \frac{12}{5}\beta_2 - \frac{16}{15}\beta_3 + \frac{19}{5}\beta_7 + \frac{68}{15}\beta_8 + 3\beta_9 + \frac{2}{3}\beta_{10} \\ &\quad - \frac{4}{3}\beta_{11} - \frac{43}{15}\beta_{12} - \frac{9}{5}\beta_{19} + \frac{7}{3}\beta_{20} + \frac{11}{3}\beta_{21}, \\ \omega_{22} &= -\frac{35}{48} - \frac{1}{2}\alpha_0 + \beta_2 + \beta_3 + \frac{2}{3}\beta_8 + \beta_9 + \frac{4}{3}\beta_{10} + \beta_{11} + \frac{2}{3}\beta_{12}, \\ \omega_{23} &= \frac{5837}{960} - \frac{29}{80}\alpha_0 + \frac{1}{60}\alpha_2 - \frac{77}{20}\beta_1 - \frac{23}{5}\beta_2 - \frac{11}{15}\beta_3 - \frac{47}{10}\beta_7 - \frac{34}{5}\beta_8 - \frac{23}{4}\beta_9 - \frac{7}{2}\beta_{10} \\ &\quad - \frac{11}{12}\beta_{11} + \frac{9}{5}\beta_{12} + \frac{9}{20}\beta_{19} - \frac{13}{3}\beta_{20} - \frac{14}{3}\beta_{21}, \\ \omega_{24} &= -\frac{5203}{960} + \frac{31}{80}\alpha_0 + \frac{1}{60}\alpha_2 + \frac{83}{20}\beta_1 + \frac{17}{5}\beta_2 - \frac{11}{15}\beta_3 + \frac{53}{10}\beta_7 + \frac{31}{5}\beta_8 + \frac{17}{4}\beta_9 + \frac{3}{2}\beta_{10} \\ &\quad - \frac{11}{12}\beta_{11} - \frac{16}{5}\beta_{12} + \frac{9}{20}\beta_{19} + \frac{14}{3}\beta_{20} + \frac{13}{3}\beta_{21}, \\ \omega_{25} &= \frac{35}{48} + \frac{1}{2}\alpha_0 - \beta_1 + \beta_3 - \beta_7 - \frac{2}{3}\beta_8 + \frac{2}{3}\beta_{10} + \beta_{11} + \frac{4}{3}\beta_{12}, \\ \omega_{26} &= \frac{53}{40} - \frac{9}{5}\alpha_0 - \frac{16}{15}\alpha_2 - \frac{3}{5}\beta_1 - \frac{8}{5}\beta_2 - \frac{16}{15}\beta_3 - \frac{6}{5}\beta_7 - \frac{32}{15}\beta_8 - 2\beta_9 - \frac{5}{3}\beta_{10} - \frac{4}{3}\beta_{11} - \frac{8}{15}\beta_{12} - \frac{9}{5}\beta_{19} - \frac{11}{3}\beta_{20} - \frac{7}{3}\beta_{21}, \\ \omega_{27} &= -\frac{77}{64} + \frac{3}{16}\alpha_0 + \frac{13}{12}\alpha_2 + \frac{3}{4}\beta_1 + \beta_2 + \frac{1}{3}\beta_3 + \frac{3}{2}\beta_7 + \frac{5}{3}\beta_8 + \frac{5}{4}\beta_9 + \frac{5}{6}\beta_{10} + \frac{5}{12}\beta_{11} - \frac{1}{3}\beta_{12} + \frac{9}{4}\beta_{19} + \frac{7}{3}\beta_{20} + \frac{2}{3}\beta_{21}, \\ \omega_{28} &= -\omega_{19}, \quad \omega_{29} = -\omega_{20}, \quad \omega_{30} = -\omega_{21}, \quad \omega_{31} = -\omega_{22}, \quad \omega_{32} = -\omega_{23}, \\ \omega_{33} &= -\omega_{24}, \quad \omega_{34} = -\omega_{25}, \quad \omega_{35} = -\omega_{26}, \quad \omega_{36} = -\omega_{27},\end{aligned}$$

where  $\alpha_0, \alpha_2, \beta_j, j \in \{1, 2, 3, 7, 8, 9, 10, 11, 12, 19, 20, 21\}$  are free parameters.

## References

- [1] I.J. Schoenberg, Contribution to the problem of approximation of equidistant data by analytic functions. Part A. On the problem of smoothing or graduation. A first class of analytic approximation formulae, *Quart. Appl. Math.* 4 (1946) 45–99.
- [2] C. de Boor, K. Höllig, S. Riemenschneider, *Box Splines*, Springer-Verlag, New York, 1993.
- [3] C.K. Chui, *Multivariate Splines*, in: CBMS-NSF Regional Conference Series in Applied Mathematics, vol. 54, SIAM, Philadelphia, 1988.
- [4] R.A. DeVore, G.G. Lorentz, *Constructive Approximation*, Springer-Verlag, Berlin, 1993.
- [5] M.J. Lai, L.L. Schumaker, *Spline Functions on Triangulations*, Cambridge University Press, 2007.
- [6] L.L. Schumaker, *Spline Functions. Basic Theory*, John Wiley & Sons, New York, 1981.
- [7] R.H. Wang, *Multivariate Spline Functions and Their Applications*, Science Press, Beijing, 2001; New York, Kluwer Academic Publishers, Dordrecht, Boston, London.
- [8] D. Barrera, M.J. Ibáñez, P. Sablonnière, D. Sbibih, Near minimally normed spline quasi-interpolants on uniform partitions, *J. Comput. Appl. Math.* 181 (2005) 211–233.
- [9] D. Barrera, M.J. Ibáñez, P. Sablonnière, D. Sbibih, Near-best univariate spline discrete quasi-interpolants on non-uniform partitions, *Constr. Approx.* 28 (2008) 237–251.
- [10] D. Barrera, M.J. Ibáñez, Bernstein-Bézier representation and near-minimally normed discrete quasi-interpolation operators, *Appl. Numer. Math.* 58 (2008) 59–68.
- [11] E.B. Ameer, D. Barrera, M.J. Ibáñez, D. Sbibih, Near-best operators based on a  $C^2$  quartic spline on the uniform four-directional mesh, *Math. Comput. Simulation* 77 (2008) 151–160.
- [12] D. Barrera, M.J. Ibáñez, P. Sablonnière, D. Sbibih, Near-best quasi-interpolants associated with  $H$ -splines on a three-direction mesh, *J. Comput. Appl. Math.* 183 (2005) 133–152.
- [13] D. Barrera, M.J. Ibáñez, P. Sablonnière, D. Sbibih, On near-best discrete quasi-interpolation on a four-directional mesh, *J. Comput. Appl. Math.* 233 (2010) 1470–1477.
- [14] S. Remogna, Constructing good coefficient functionals for bivariate  $C^1$  quadratic spline quasi-interpolants, in: M. Daehlen, et al. (Eds.), LNCS 5862, *Mathematical Methods for Curves and Surfaces*, Springer-Verlag, Berlin Heidelberg, 2010, pp. 329–346.
- [15] D. Barrera, M.J. Ibáñez, S. Remogna, On the construction of trivariate near-best quasi-interpolants based on  $C^2$  quartic splines on type-6 tetrahedral partitions, *J. Comput. Appl. Math.* 311 (2017) 252–261.

- [16] D. Barrera, C. Dagnino, M.J. Ibáñez, S. Remogna, Trivariate near-best blending spline quasi-interpolation operators, *Numer. Algorithms* 78 (2018) 217–241.
- [17] C. Dagnino, P. Lamberti, S. Remogna, Near-best  $C^2$  quartic spline quasi-interpolants on type-6 tetrahedral partitions of bounded domains, *Calcolo* 52 (2015) 475–494.
- [18] S. Remogna, Quasi-interpolation operators based on the trivariate seven-direction  $C^2$  quartic box spline, *BIT* 51 (2011) 757–776.
- [19] C. Manni, P. Sablonnière, Quadratic spline quasi-interpolants on Powell–Sabin partitions, *Adv. Comput. Math.* 26 (2007) 283–304.
- [20] S. Remogna, Bivariate  $C^2$  cubic spline quasi-interpolants on uniform Powell–Sabin triangulations of a rectangular domain, *Adv. Comput. Math.* 36 (2012) 39–65.
- [21] D. Sbibih, A. Serghini, A. Tijini, Polar forms and quadratic spline quasi-interpolants on Powell–Sabin partitions, *Appl. Numer. Math.* 59 (2009) 938–958.
- [22] H. Speelers, Multivariate normalized Powell–Sabin B-splines and quasi-interpolants, *Comput. Aided Geom. Design* 30 (2013) 2–19.
- [23] T. Lyche, C. Manni, P. Sablonnière, Quasi-interpolation projectors for box splines, *J. Comput. Appl. Math.* 221 (2008) 416–429.
- [24] D. Dagnino, S. Remogna, P. Sablonnière, On the solution of Fredholm integral equations based on spline quasi-interpolating projectors, *BIT* 54 (2014) 979–1008.
- [25] T. Sorokina, F. Zeilfelder, Optimal quasi-interpolation by quadratic  $C^1$  splines on four-directional meshes, in: C. Chui, et al. (Eds.), *Gatlinburg 2004*, in: *Approximation Theory*, vol. XI, Nashboro Press, Brentwood, 2004, pp. 423–438.
- [26] T. Sorokina, F. Zeilfelder, Local quasi-interpolation by cubic  $C^1$  splines on type-6 tetrahedral partitions, *IMA J. Numer. Anal.* 27 (2007) 74–101.
- [27] T. Sorokina, F. Zeilfelder, An explicit quasi-interpolation scheme based on  $C^1$  quartic splines on type-1 triangulations, *Comput. Aided Geom. Design* 25 (2008) 1–13.
- [28] C. de Boor, K. Höllig, Bivariate box splines and smooth pp functions on a three direction mesh, *J. Comput. Appl. Math.* 9 (1983) 13–28.
- [29] C. de Boor, R.Q. Jia, A sharp upper bound on the approximation order of smooth bivariate pp functions, *J. Approx. Theory* 72 (1993) 24–33.
- [30] R.Q. Jia, Approximation order from certain spaces of smooth bivariate splines on a three-direction mesh, *Trans. Amer. Math. Soc.* 295 (1986) 199–212.
- [31] M. Hering-Bertram, G. Reis, F. Zeilfelder, Adaptive quasi-interpolating quartic splines, *Computing* 86 (2009) 89–100.