



A new host for a new *Rossomyrmex minuchae* population

O. Sanllorente¹ · A. Lenoir² · E. Perdereau² · F. Ruano¹ · F. M. Azcárate³ · M. Silvestre³ · P. Lorite⁴ · A. Tinaut¹

Received: 27 September 2022 / Revised: 19 April 2023 / Accepted: 2 May 2023
© The Author(s) 2023

Abstract

Social parasites usually rely on chemical cues (cuticular hydrocarbons) to successfully invade and coexist with their hosts. Most ants that are obligate social parasites (slave-makers) can parasitize several related host species with different levels of chemical similarity although there are few exceptions where there is only a single host species. An example of the latter is *Rossomyrmex minuchae*, which was known to be only associated with *Proformica longiseta*. However, a recent discovery of a new *R. minuchae* population revealed that it can parasitize *P. nasuta*, a species with a separate distribution to *P. longiseta*. Chemical analyses of cuticular hydrocarbons show local adaptation of the parasite to its host in this new population, being more similar to *P. nasuta* than to other *R. minuchae* populations. In addition, genetic analyses evidence differences from the other known populations, from which it split 1.21 Mya during glacial and interglacial periods of the Pleistocene and remained separated to the present day. This historical genetic isolation and the chemical differences found between parasite populations may evidence a speciation process and support the local host–parasite coevolution.

Keywords Cuticular hydrocarbons · Host–parasite coevolution · *Rossomyrmex* · Slave-making ants

Introduction

Slave-making ants are obligate social parasites that depend on another ant species (the host) to survive and whose main strategies are: (1) gynes taking over a host nest by chemical mimicry and (2) workers periodically raiding on other host nests to replenish the labor force as slaves (Hölldobler and Wilson 1990; de la Mora et al. 2020). Within the mixed nest, the relationship between parasite and host is mostly peaceful because their recognition cues, cuticular hydrocarbons (CHCs) are similar and, thus, prevent them from aggression (Guerrieri et al. 2009; van Zweden and d’ettorre 2010). This chemical similarity is achieved by local co-adaptation or by

acquisition of the host’s chemical profile by the parasite of (see review by Lenoir et al. 2001). In this sense, the study of parasite’s and host’s CHCs profiles provides useful information about how successful the parasite is in mimicry and could provide an estimate of their coevolutionary time (see Ruano et al. 2011).

Usually, slave-making ants parasitize multiple host species that are close relatives: same tribe but different genus (see Huang and Dornhaus 2008). One of the few exceptions that seemed to have a single host species is *Rossomyrmex minuchae*, a slave-making ant described and studied in three high mountains of South-eastern Spain: Sierra Nevada (S), Sierra de Gádor (G) and Sierra de Filabres (F) (Sanllorente et al. 2010, 2012). In these populations, the species parasitizes *Proformica longiseta* exclusively. Nevertheless, *R. minuchae* has been recently found in Guadarrama mountains (Central Spain) but in this case parasitizing another species, *Proformica nasuta* (Azcárate et al. 2016), thus representing the first reported case of host change for the species. The geographical distribution of both host species is clearly exclusive, being *P. longiseta* endemic to the South East of the Iberian Peninsula and present above 1800–2700 m a.s.l. (Fernández-Escudero and Tinaut 1998), whereas *P. nasuta* shows a

✉ O. Sanllorente
oli@ugr.es

¹ Department of Zoology, University of Granada, Granada, Spain

² IRBI, Institut de Recherche sur la Biologie de l’Insecte, UMR CNRS 7261, University of Tours, Tours, France

³ Department of Ecology, Autonomous University of Madrid, Madrid, Spain

⁴ Department of Experimental Biology, University of Jaén, Jaén, Spain

patchy distribution in Spain and Southern France at lower altitudes (de Haro and Collingwood 1991; Galkowski et al. 2017, see also (Galkowski et al. 2022 for a new species in the Pyrenees). This disjunct hosts distribution means that *R. minuchae* has no choice on what host species parasitize and may have forced *R. minuchae* to develop a local adaptation for successfully enslaving each host species. In host–parasite social systems, the parasite is usually the one shaping its chemical profile to mimic its host’s and this not only happens in ants (e.g., Brandt et al. 2005), but also in other Hymenoptera like *Bombus* (Martin et al. 2010).

In this study, we investigate the coevolution between *R. minuchae* and *P. nasuta* using cuticular hydrocarbons, the key for nest mate recognition and their behavioral interaction. We also analyze the mitochondrial gene Cytochrome Oxidase I (COI) of the new *R. minuchae* population and compare it with the other known *Rossomyrmex* populations to have a complete knowledge of the genus diversity. Furthermore, we estimate a timetree for the slave-making species and populations to determine the split of the Central and Southern populations. The presence of *R. minuchae* in this new locality in the center of the Iberian Peninsula opens the possibility to better understand the origin and dispersal routes of the genus *Rossomyrmex* in Eurasia and more specifically in the Iberian Peninsula and the host switch between both species of *Proformica* (*P. longiseta* and *P. nasuta*).

Materials and methods

Three *Rossomyrmex minuchae* nests were sampled in July 2016 in Sierra de Guadarrama, Central Spain (Puerto de Canencia UTM coordinates: 30 T 436,000 4,524,000; 1485 m a.s.l.; Fig. 1). We abbreviate this population as N for further analyses. From each of these nests, we collected 13 parasites and 13 hosts (*P. nasuta*) (Azcárate et al. 2016). In addition, we collected 13 workers from five sympatric free-living host nests (within 50 m from the parasitized nests) as well as from five allopatric free-living host nests in another close location where *R. minuchae* has never been found (Azcárate and Seoane pers. comm.; Soto del Real UTM coordinates: 30 T 431,717 4,513,580; 1015 m a.s.l.). For this work, we will also include data from *R. minuchae*-*P. longiseta* Southern populations: Sierra Nevada, Gador and Filabres (SN, G and F, respectively; Fig. 1). Chemical and genetic data on these Southern populations were previously analyzed in Ruano et al. 2011; Sanllorente et al. 2012, respectively.

For the cuticular hydrocarbon analyses, five workers from each of the studied colonies were killed by freezing (total number of individuals = 80). All the ants were immersed in 1 ml of hexane for 60 min, after which the ants were retrieved from the vials and the solvent evaporated. The samples were kept frozen at $-20\text{ }^{\circ}\text{C}$ until chemical analyses. For analysis, the samples were re-dissolved in 50 μl of

Fig. 1 Studied localities where *R. minuchae* is found



hexane. Using an autosampler (Gerstel, Mühleim an der Ruhr, Germany), 2 μ l of each extract were injected into a GC/MS QQQ Agilent (GC 78,908, MS 7000C) operating at 70 eV with a source temperature of 230 °C equipped with a Zebtron ZB-5HT column (30 mL \times 0.25 mm ID \times 0.25 μ m df; 5% Phenyl–95% Dimethylpolysiloxane, Phenomenex, Torrance, CA, USA). The GC oven temperature program was 2 min at 60 °C, and then increasing at 5 °C/min to 320 °C, and 5 min hold at 320 °C (total 46 min). The gas vector was helium at 2.0 ml/min. Compounds were identified by their fragmentation pattern, compared to standard alkanes (C₁₀ and all even n-alkanes from C₂₀ to C₄₀, 50 mg/l in n-heptane each, Supelco®) and library data (NIST, National Institute of Standards and Technology,) using MassHunter Qualitative Analysis software (Agilent Technologies). All the measurements (raw abundance) are provided as mean% \pm SE (Standard Error). The data (abundance of peaks in %) were analyzed using cluster analysis on Euclidian distances and the Ward method (Statistica 8.0 program). We also calculated the equivalent chain length (ECL; see Martin et al. 2019) which indicates the mean of hydrocarbons length = $(\sum (\%C_{n:1} \times n))/100$, where C_n is the carbon number

of the hydrocarbon (for example C₂₇ C_n = 27 and 3-meC₂₇ C_n = 28) and xn is the percentage of quantity of this hydrocarbon. ECL is not sufficient to discriminate species but is a good indication to classify them in groups. Additionally, we compared the cuticular profile in abundance and absence/presence of peaks of the different *R. minuchae* populations in the Iberian Peninsula (Fig. 2).

For the analysis of the mitochondrial COI gene, only a single *R. minuchae* individual per nest was analyzed. Both chemical extractions and analysis as well as genetic lab procedures were performed following the protocol described in Sanllorente et al. 2012. COI chromatograms were checked by eye using the software Chromas Lite 2.01 (Technelysium Pty Ltd). Two of the three nests shared the same COI haplotype, so we only considered two COI sequences for further analyses. Sequences N1 and N2 were aligned together with all the published COI sequences of *Rossomyrmex* (Sanllorente et al. 2012) as well as with COI sequences of *Formica wheeleri*, *Formica moki* and *Colobopsis conithorax* (GenBank accession numbers: DQ353362, AF398151, EF653271 respectively) with ClustalW implemented in the program BioEdit v.7.1.11 (Hall 1999). Substitution models,

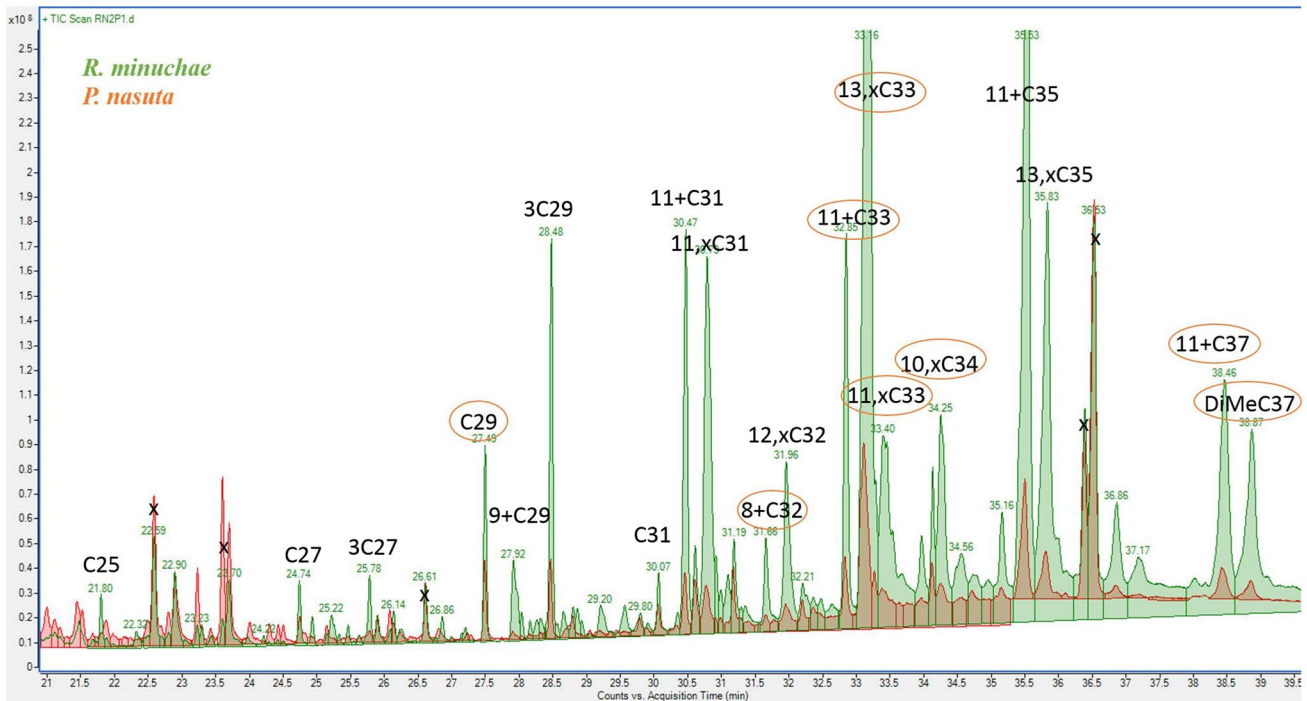

Fig. 2 Gas chromatograms of *R. minuchae* (green profile) and enslaved *P. nasuta* (red profile) from Guadarrama population. Y axis is abundance and X axis the time. The abbreviations of the peaks correspond to: 3C27 = 3-meC27; 9 + C29 = 9 + 11 + 13 + 15-meC29; 3C29 = 3-meC29; 11 + C31 = 11 + 13 + 15 + 16-meC31; 11,xC31 = 11,13 + 11,15 + 11,17-dimeC31; 8 + C32 = 8 + 10 + 11 + 12 + 13 + 14me C32; 12,xC32 = 12,14 + 12,16-dimeC32; 11 + C33 = 11 + 13 + 15 + 1

7-meC33; 13,xC33 = 13,15-dimeC33; 11,xC33 = 11,13 + 11,15-dimeC33; 10,xC34 = 10,14 + 10,16 + 12,14-dimeC34; 11 + C35 = 11 + 13-meC35; 13,xC35 = 13,15 + 13,17 + 15,17-dimeC35; 11 + C37 = 11 + 13 + 17-meC37; x,x-dimeC37: positions not determined. X correspond to phthalates and sterols pollutions not included in the HCs analysis. Red circles indicate significant differences (Kruskal–Wallis $p < 0.05$)

sequence variation and genetic distances were performed with MEGA X (Kumar et al. 2018). The best substitution model under the Bayesian information criterion (BIC) was HKY + I (Hasegawa et al. 1985). The same program was used to estimate a maximum likelihood (ML) tree performing 1000 bootstrap replicates and a timetree. The timetree was inferred using the RelTime-ML method (Tamura et al. 2018) and the HKY + I model; *C. conithorax* was set as out-group and the divergence time between *F. wheeleri* and *F. moki* (9.2 Mya; Moreau et al. 2006) was used as a calibration constraint (available at <http://www.timetree.org/>) (Kumar et al. 2017).

Results

Description of the *R. minuchae* chromatograms from the new central population showed a similar cuticular profile to their enslaved *P. nasuta* (Fig. 2). Nevertheless, each species maintains its own profile, with different compound quantities and distinguishable identity (see Table S1 for full compound information). The peaks C29, 8 + 10 + 11 + 12 + 13 + 14-m eC32, 11 + 13 + 15 + 17-meC33, 11,13 + 11,15-dimeC33, 10,14 + 10,16 + 12,14-dimeC34, 11 + 13 + 17-meC37 and x,x-dimeC37 show significant differences (Kruskal-Wallis

$p < 0.05$), whereas peaks 3-meC29, 11 + 13-meC35 and 13,15 + 13,17 + 15,17-dimeC35 do not, due to the high variability of the samples.

The cluster analysis including all the *R. minuchae*-host populations showed that the parasite populations are closer to their local hosts than to other *R. minuchae* (Fig. 3). In addition, the one parasitizing *P. nasuta* is also closer to unparasitized *P. nasuta* populations from France than to the Southern *R. minuchae* populations. When we analyze ECL the *Rossomyrmex* group (RN) has the highest level of all ants, but the differences are only significant when compared to the allopatric potential hosts (Kruskal-Wallis $p = 0.53$, RN = 33.16 ± 0.34 , SyN = 31.58 ± 0.46 , EN = 31.96 ± 0.31 , AN 30.51 ± 0.62 and RN/AN $p = 0.038$).

R. minuchae COI sequences were translated into aminoacids and checked for stop codons. They consisted of 548 nucleotide positions, 71 of them being variable and 64 parsimony informative polymorphic sites. Nucleotide composition was clearly A-T biased (66.3%), especially at the third codon position (81.5%). Transitions were higher than transversions (Ti/Tv = 6.2). Overall distance among sequences was 4.6% ($\pm 0.5\%$ SE, p-distance) whereas the distances among the Southern *R. minuchae* populations were smaller (1.3–2.9%) than the distances among these populations and the Central population (3.3–3.7%)

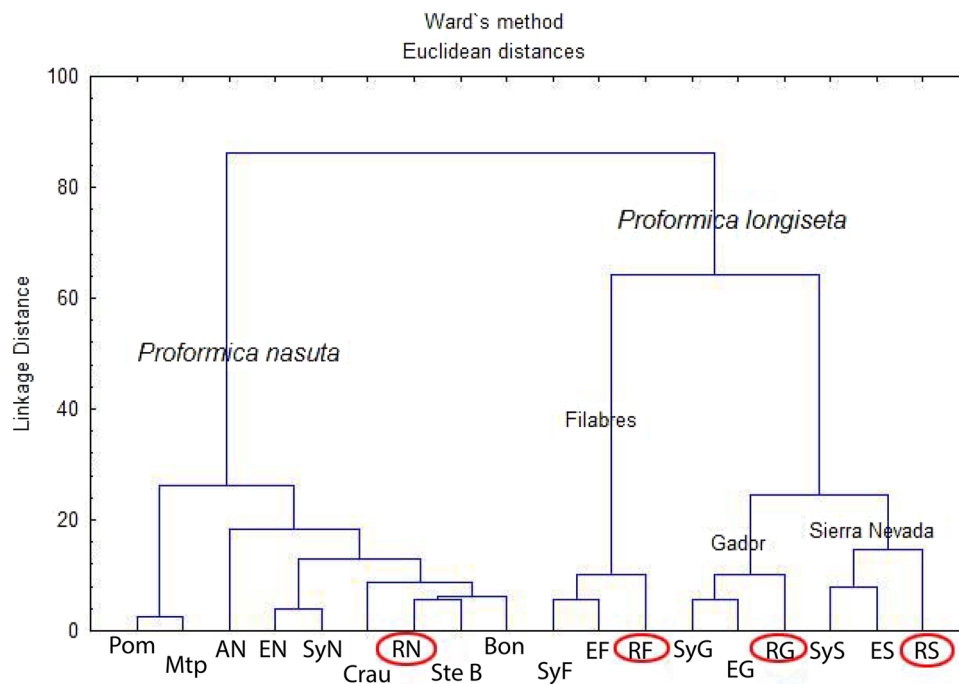

Fig. 3 Dendrogram (Ward method, Euclidean distances) of the cuticular hydrocarbons of the *R. minuchae* populations (RN from Guadarama, RF from Filabres, RG from Gador and RS from Sierra Nevada) in circles and their host species: *P. longiseta* (from enslaved nests: (EF, EG and ES from Filabres, Gador and Sierra Nevada, respectively) and sympatric free-living nests (SyF, SyG and SyS from

Filabres, Gador and Sierra Nevada, respectively) and *P. nasuta* from Central Spain (EN, SyN and AN, from enslaved nests, sympatric free-living nests and allopatric free-living nests, respectively) and France (Pom, Ptp, Crau, Ste B and Bon, from Pompignan, Montpellier, plain of Crau, Sainte Baume mountain and Bonnieux, respectively; see Galkowski et al. 2017)

Table 1 Mean pairwise genetic distances (p-distance) between *Rossomyrmex* populations are shown under the diagonal and standard errors above diagonal

	<i>R. quadratinodum</i>	<i>R. anatolicus</i>	<i>R. minuchae S</i>	<i>R. minuchae F</i>	<i>R. minuchae G</i>	<i>R. minuchae N</i>
<i>R. quadratinodum</i>		0.008	0.012	0.011	0.011	0.011
<i>R. anatolicus</i>	0.041		0.011	0.010	0.010	0.010
<i>R. minuchae S</i>	0.086	0.072		0.005	0.007	0.008
<i>R. minuchae F</i>	0.085	0.068	0.013		0.006	0.007
<i>R. minuchae G</i>	0.086	0.068	0.029	0.024		0.007
<i>R. minuchae N</i>	0.089	0.070	0.037	0.033	0.034	

For *R. minuchae*, the initials S, F, G and N correspond to the localities Sierra Nevada, Filabres, Gador and Guadarrama, respectively

(Table 1; see Table S2 for all pairwise mean distances). These data are in concordance with the phylogenetic analyses (see Fig. 4). The three Southern populations cluster together in a well-supported clade, separated from the Central *R. minuchae* population. Anyway, all *R. minuchae* populations were grouped in a well-supported clade (100).

The timetree estimated that the divergence time between the Central and Southern populations is around 1.21 Mya (Fig. 5). Within the Southern populations, Gador diverged from the others about 0.67 Mya whereas Sierra Nevada and Filabres split only 0.22 Mya. In addition, the timetree also showed quite similar divergence times between the Asian species (*R. quadratinodum* and *R. anatolicus*) and between these two and *R. minuchae* (4.50 and 4.84 Mya, respectively).

Discussion

Our study evidences that the Central population of *R. minuchae* is to some extent locally adapted to its host *P. nasuta* in a similar way that the Southern populations are adapted to *P. longiseta*. In agreement to our previous work with Southern populations (see Ruano et al. 2011), the chemical profiles of enslaved and sympatric free-living host colonies in Central populations, are very similar but different to some point from those of *R. minuchae* and this difference is larger when compared with allopatric free-living hosts. However, the fact that the new *R. minuchae* population is closer to unparasitized *P. nasuta* populations from France, points to an ongoing coevolutionary tuning between host and parasite that has not been completed (local adaptation). The current situation may indicate a higher probability of aggression between host and parasite during the raids and thus, of

Fig. 4 Maximum likelihood phylogenetic tree for all *Rossomyrmex* known populations (for *R. minuchae*, SN corresponds to Sierra Nevada population, F to Filabres, G to Gador and N to Guadarrama) with their Genbank accession numbers

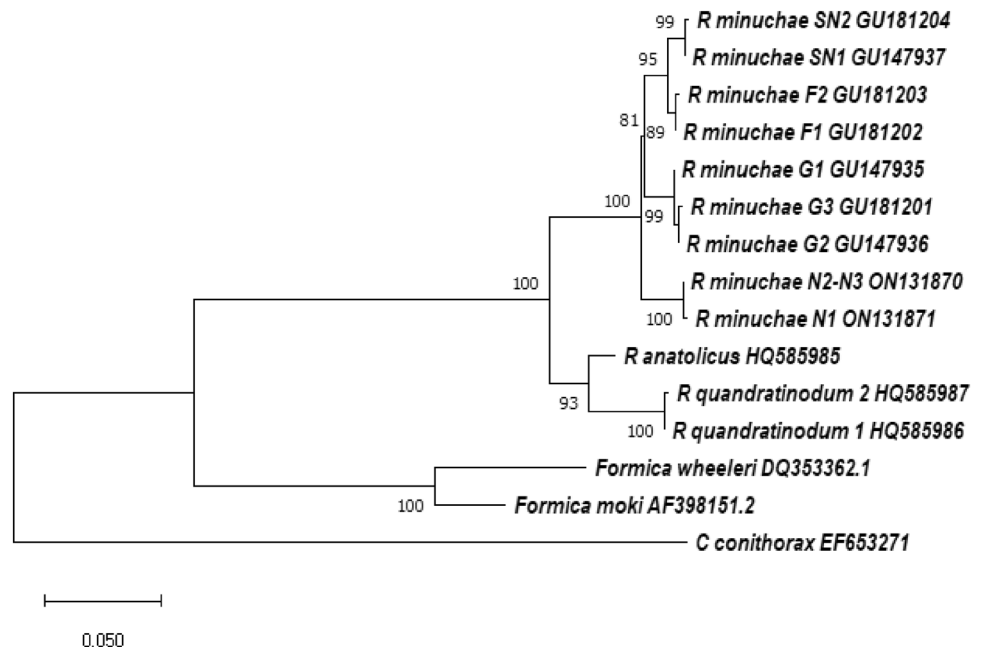
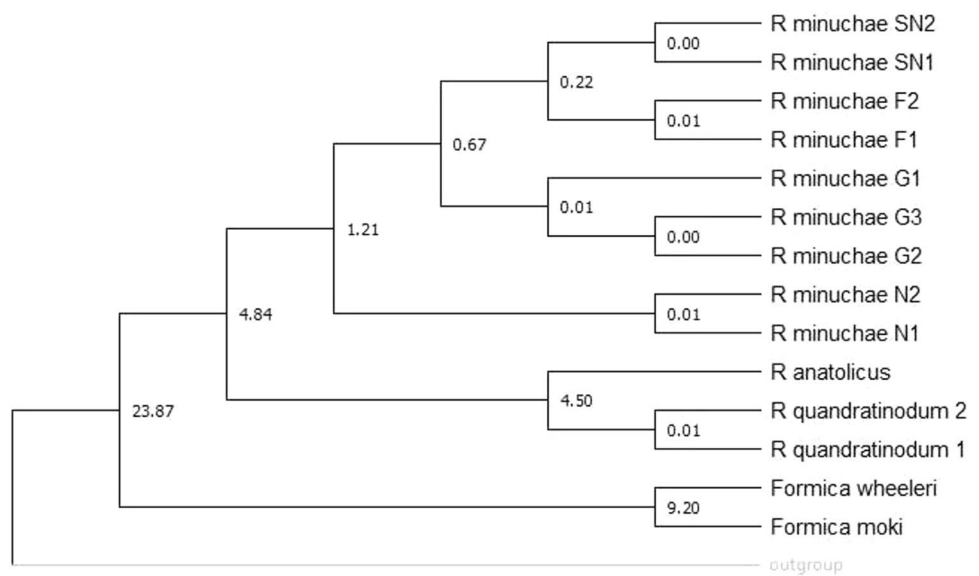

Fig. 5 Estimated timetree for all *Rossomyrmex* analyzed (for *R. minuchae*, SN corresponds to Sierra Nevada population, F to Filabres, G to Gador and N to Guadarrama). The outgroup corresponds to *Colobopsis conithorax*. The distance between both *Formica* species was used as calibration constraint



host nests death. In the Southern populations, natural selection acted on local hosts' CHC so that those more similar to the parasite would be less aggressive and survive the raids, whereas the more different would be killed (Zamora-Muñoz et al. 2003; Errard et al. 2006). Another possible scenario would be that those parasites more similar to the host species would succeed in parasitizing whereas those too different would eventually disappear. In this sense, different coevolutionary outcomes have been demonstrated for the three Southern populations (with different CHC distances between local parasites and hosts; see Ruano et al. 2011), as well as for other slave-making ants with more than one host species and showing chemical specialization (Brandt et al. 2005; Bauer et al. 2010). Furthermore, another *Proformica* species inhabits South-eastern Spain at low altitudes, *P. ferreri*, but at the present moment is not known to be parasitized by *R. minuchae*. This could be due to several reasons: (1) that the chemical profiles of both *Proformica* are so different that it is not possible for the parasite to closely adapt to two hosts at the same time, a situation previously described for the slavemaker *Harpagoxenus sublaevis* (Bauer et al. 2010); (2) that *P. ferreri* was not successfully parasitized in the past as it happens in *Polyergus* and their potential hosts (Mori et al. 1994, 1995); or (3) microclimatic conditions forced the parasite to live in high mountains, preventing *P. ferreri* from parasitism.

On the other hand, and in line with chemical profiles, genetic analyses show that the Central *R. minuchae* population is well differentiated from the Southern ones. Further, the distance between Central and Southern populations is slightly bigger than the distances among the latter. This result is also supported by the divergence time estimated (1.21 Mya) and probably favored by the longer geographical distance and subsequent population

isolation during glacial and interglacial periods of the Pleistocene. During glacial periods probably both populations remained separated in different Iberian refuges (Tinaut and Ruano 2021) and in interglacial periods they climbed to different range mountains. This scenario of long-term isolation may suggest an allopatric speciation process going on in *R. minuchae* evidenced by the clear chemical and genetic differentiation found between Central and Southern populations. The host change detected between both populations will also make a *R. minuchae* populations remixing difficult in case of a hypothetical reunion (glaciation). On the other hand, the *R. minuchae* population isolated in the Southern Iberian refuges found there the *P. longiseta* species suitable for parasitizing. Host cuticular plasticity permitted the local adaptation of each sympatric *P. longiseta* to *R. minuchae* populations, and the occurrence of a geographical mosaic of coevolution in the high-mountain ranges of South-eastern Spain (Ruano et al. 2011).

In addition, our results point that the Asian and Iberian clades split during the cold early Pliocene (4.84 Mya), a period in which both Asian clades (*R. anatolicus* and *R. quadratinodum*) shortly after also split (4.50 Mya). This would be in agreement with our previous results suggesting a Southern Europe origin for the *Rossomyrmex* clade (Sanllorente et al. 2018).

In conclusion, the new population of the slave-making ant *R. minuchae* found in Central Spain seems locally adapted to its host *P. nasuta*, as it is evidenced by chemical analyses. Furthermore, the chemical differences detected between this new population and the others present in the Southern mountains are also supported by genetic analyses, pointing to a population split in the Pleistocene and a possible speciation process going on.

Supplementary Information The online version contains supplementary material available at <https://doi.org/10.1007/s00040-023-00916-5>.

Acknowledgements M Silvestre and FM Azcárate received administrative and financial support from the Spanish Ministry of Economy and Competitiveness (Project CGL2014-53789-R). Sierra de Guadarrama National Park provided the permits for the sampling (ref 10/101642.9/16). This work was also partially funded by the University of Jaén through the “Plan Operativo de Apoyo a la Investigación 2021-2022”.

Author contributions All authors contributed to the study conception and design. Sample collection was carried out by AT, FR, FMA and MS. Data analyses were performed by OS, PL, AL and EP. The first draft of the manuscript was written by OS and all authors commented on previous versions of the manuscript. All authors read and approved the final manuscript.

Funding Funding for open access publishing: Universidad de Granada/CBUA.

Data availability Genetic data can be accessed at GenBank. Other data reported in this manuscript can be consulted upon request to the corresponding author.

Declarations

Conflict of interest The authors declare that there are no conflicts of interest regarding this manuscript.

Open Access This article is licensed under a Creative Commons Attribution 4.0 International License, which permits use, sharing, adaptation, distribution and reproduction in any medium or format, as long as you give appropriate credit to the original author(s) and the source, provide a link to the Creative Commons licence, and indicate if changes were made. The images or other third party material in this article are included in the article's Creative Commons licence, unless indicated otherwise in a credit line to the material. If material is not included in the article's Creative Commons licence and your intended use is not permitted by statutory regulation or exceeds the permitted use, you will need to obtain permission directly from the copyright holder. To view a copy of this licence, visit <http://creativecommons.org/licenses/by/4.0/>.

References

Azcárate F, Rota C, Hevia V et al (2016) Primera cita de *Rossomyrmex minuchae* Tinaut, 1981 (Hymenoptera, Formicidae) en el Sistema Central (España). *Bol Asoc Esp Entomol* 40:535–537

Bauer S, Böhm M, Witte V, Foitzik S (2010) An ant social parasite in-between two chemical disparate host species. *Evol Ecol* 24:317–332. <https://doi.org/10.1007/s10682-009-9308-2>

Brandt M, Heinze J, Schmitt T, Foitzik S (2005) A chemical level in the coevolutionary arms race between an ant social parasite and its hosts. *J Evol Biol* 18:576–586. <https://doi.org/10.1111/j.1420-9101.2004.00867.x>

de Haro A, Collingwood CA (1991) Prospección mirmecologica en la Cordillera Ibérica

de la Mora A, Sankovitz M, Purcell J (2020) Ants (Hymenoptera: Formicidae) as host and intruder: recent advances and future directions in the study of exploitative strategies. *Myrmecol News*. https://doi.org/10.25849/myrmecol.news_030:053

Dronnet S, Lohou C, Christides J-P, Bagnères A-G (2006) Cuticular hydrocarbon composition reflects genetic relationship among

colonies of the introduced termite *Reticulitermes santonensis* feytaud. *J Chem Ecol* 32:1027–1042. <https://doi.org/10.1007/s10886-006-9043-x>

Errard C, Ruano F, Richard F-J et al (2006) Co-evolution-driven cuticular hydrocarbon variation between the slave-making ant *Rossomyrmex minuchae* and its host *Proformica longiseta* (Hymenoptera: Formicidae). *Chemoecology* 16:235–240. <https://doi.org/10.1007/s00049-006-0358-4>

Fernández-Escudero I, Tinaut A (1998) Heat-cold dialectic in the activity of *Proformica longiseta*, a thermophilous ant inhabiting a high mountain (Sierra Nevada, Spain). *Int J Biometeorol* 41:175–182. <https://doi.org/10.1007/s004840050072>

Galkowski C, Lebas C, Wegnez P et al (2017) Redescription of *Proformica nasuta* (Nylander, 1856) (Hymenoptera, Formicidae) using an integrative approach. *Eur J Taxon*. <https://doi.org/10.5852/ejt.2017.290>

Galkowski C, Lebas C, Lenoir A et al (2022) Description d'une nouvelle espèce de *Proformica* (Hymenoptera, Formicidae), *P. cerdanyensis* n. sp., dans les Pyrénées. *Rev Assoc Roussillonnaise Entomol* 31:26–42

Guerrieri FJ, Nehring V, Jørgensen CG et al (2009) Ants recognize foes and not friends. *Proc R Soc B Biol Sci* 276:2461–2468. <https://doi.org/10.1098/rspb.2008.1860>

Hall TA (1999) BioEdit: a user-friendly biological sequence alignment editor and analysis program for Windows 95/98/NT. *Nucleic Acids Symp Ser* 41:95–98

Hasegawa M, Kishino H, Yano T (1985) Dating of the human-ape splitting by a molecular clock of mitochondrial DNA. *J Mol Evol* 22:160–174. <https://doi.org/10.1007/BF02101694>

Hölldobler B, Wilson EO (1990) The ants. Harvard University Press

Huang MH, Dornhaus A (2008) A meta-analysis of ant social parasitism: host characteristics of different parasitism types and a test of Emery's rule. *Ecol Entomol* 33:589–596. <https://doi.org/10.1111/j.1365-2311.2008.01005.x>

Kumar S, Stecher G, Suleski M, Hedges SB (2017) TimeTree: a resource for timelines, timetrees, and divergence times. *Mol Biol Evol* 34:1812–1819. <https://doi.org/10.1093/molbev/msx116>

Kumar S, Stecher G, Li M et al (2018) MEGA X: molecular evolutionary genetics analysis across computing platforms. *Mol Biol Evol* 35:1547–1549. <https://doi.org/10.1093/molbev/msy096>

Lenoir A, d'Etorre P, Errard C, Hefetz A (2001) Chemical ecology and social parasitism in ants. *Annu Rev Entomol* 46:573–599

Martin SJ, Carruthers JM, Williams PH, Drijfhout FP (2010) Host specific social parasites (Psithyrus) indicate chemical recognition system in bumblebees. *J Chem Ecol* 36:855–863. <https://doi.org/10.1007/s10886-010-9805-3>

Martin SJ, Drijfhout FP, Hart AG (2019) Phenotypic plasticity of nest-mate recognition cues in formica exsecta ants. *J Chem Ecol* 45:735–740. <https://doi.org/10.1007/s10886-019-01103-2>

Moreau CS, Bell CD, Vila R et al (2006) Phylogeny of the ants: diversification in the age of angiosperms. *Science* 312:101–104. <https://doi.org/10.1126/science.1124891>

Mori A, Grasso DA, D'ettorre P, le Moli F (1994) Specificity in host choice by the slave-making ant *Polyergus rufescens* Latr. (Hymenoptera Formicidae). *Ethol Ecol Evol* 6:89–93. <https://doi.org/10.1080/03949370.1994.10721979>

Mori A, D'Etterre P, le Moli F (1995) Host nest usurpation and colony foundation in the European amazon ant, *Polyergus rufescens* Latr. (Hymenoptera: Formicidae). *Insect Soc* 42:279–286. <https://doi.org/10.1007/BF01240422>

Ruano F, Devers S, Sanllorente O et al (2011) A geographical mosaic of coevolution in a slave-making host-parasite system. *J Evol Biol* 24:1071–1079. <https://doi.org/10.1111/j.1420-9101.2011.02238.x>

Sanllorente O, Hammond RL, Ruano F et al (2010) Extreme population differentiation in a vulnerable slavemaking ant with a fragmented

- distribution. *Conserv Genet* 11:1701–1710. <https://doi.org/10.1007/s10592-010-0063-2>
- Sanllorenzo O, Lorite P, Devers S et al (2012) The spatial distribution does not affect host-parasite coevolution in *Rossomyrmex* ants. *Insect Soc* 59:361–368. <https://doi.org/10.1007/s00040-012-0228-8>
- Sanllorenzo O, Lorite P, Ruano F et al (2018) Phylogenetic relationships between the slave-making ants *Rossomyrmex* and their *Proformica* hosts in relation to other genera of the ant tribe Formicini (Hymenoptera: Formicidae). *J Zool Syst Evol Res* 56:48–60. <https://doi.org/10.1111/jzs.12184>
- Tamura K, Tao Q, Kumar S (2018) Theoretical foundation of the RelTime method for estimating divergence times from variable evolutionary rates. *Mol Biol Evol* 35:1770–1782. <https://doi.org/10.1093/molbev/msy044>
- Tinaut A, Ruano F (2021) Biogeography of Iberian ants (Hymenoptera: Formicidae). *Diversity (Basel)* 13:88
- van Zweden JS, d'ettorre P, (2010) Nestmate recognition in social insects and the role of hydrocarbons. *Insect hydrocarbons: biology, biochemistry and chemical ecology*. Cambridge University Press, pp 222–242
- Zamora-Muñoz C, Ruano F, Errard C et al (2003) Coevolution in the slave-parasite system *Proformica longiseta*—*Rossomyrmex minuchae* (Hymenoptera: Formicidae). *Sociobiology* 42:299–317