

# Herramientas multidisciplinares para el estudio de la cerámica a través de la pintura de la Edad Moderna

Miguel Busto Zapico  
Universidad de Granada  
[bustomiguel@ugr.es](mailto:bustomiguel@ugr.es)

## Herramientas multidisciplinares para el estudio de la cerámica a través de la pintura de la Edad Moderna

Miguel Busto Zapico  
Universidad de Granada



UNIVERSIDAD DE GRANADA

Departamento de Historia Medieval y Ciencias y Técnicas Historiográficas  
Facultad de Filosofía y Letras



MINISTERIO DE CIENCIA E INNOVACIÓN



Financiado por la Unión Europea  
NextGenerationEU



# Herramientas multidisciplinares para el estudio de la cerámica a través de la pintura de la Edad Moderna

- Bibliografía
- ¿Por qué estudiar cerámica post-medieval?
- ¿Cómo estudiar cerámica post-medieval?
- Análisis funcional-tipológico
- Análisis tecnológico
- Principales Grupos Tecnológicos
- Principales Producciones Post-medievales
- Cerámica post-medieval y pintura





# Bibliografía



# Bibliografía básica:

- Orton, C. R. (1988). Matemáticas para arqueólogos. Madrid: Alianz Editorial.
- Orton, C. R. (2009). Four pots good, two pots bad?: exploring the limits of quantification in the study of archaeological ceramics. New Perspectives on Ancient Pottery Conference, University of Amsterdam, 1-10.
- Orton, C. R., & Hughes, M. (2013). Pottery in archaeology (2nd ed.). Cambridge: Cambridge University Press.
- Orton, C. R., Tyers, P., & Vince, A. (1997). La cerámica en arqueología. Barcelona: Crítica.
- Shennan, S. (1992). Arqueología Cuantitativa. Barcelona: Editorial Crítica.



¿Por qué estudiar  
cerámica post-medieval?



**LAS CERÁMICAS  
CAMBIAN**

**CRONOLOGÍAS  
RELATIVAS**

- Similitudes o diferencias.
- Coexistencia de tipos.
- Características diferentes.
- Tendencias de desarrollo.



**CRONOLOGÍAS  
ABSOLUTAS**

- Evidencias documentales.
- Técnicas científicas.



**LAS CERÁMICAS  
SE MUEVEN**

**OBJETO DE  
CONSUMO**

**CONTENEDORES  
COMERCIALES**



**LA CERÁMICA  
SE UTILIZA**

**FUNCIÓN**



**STATUS**



# Cerámica y cronologías

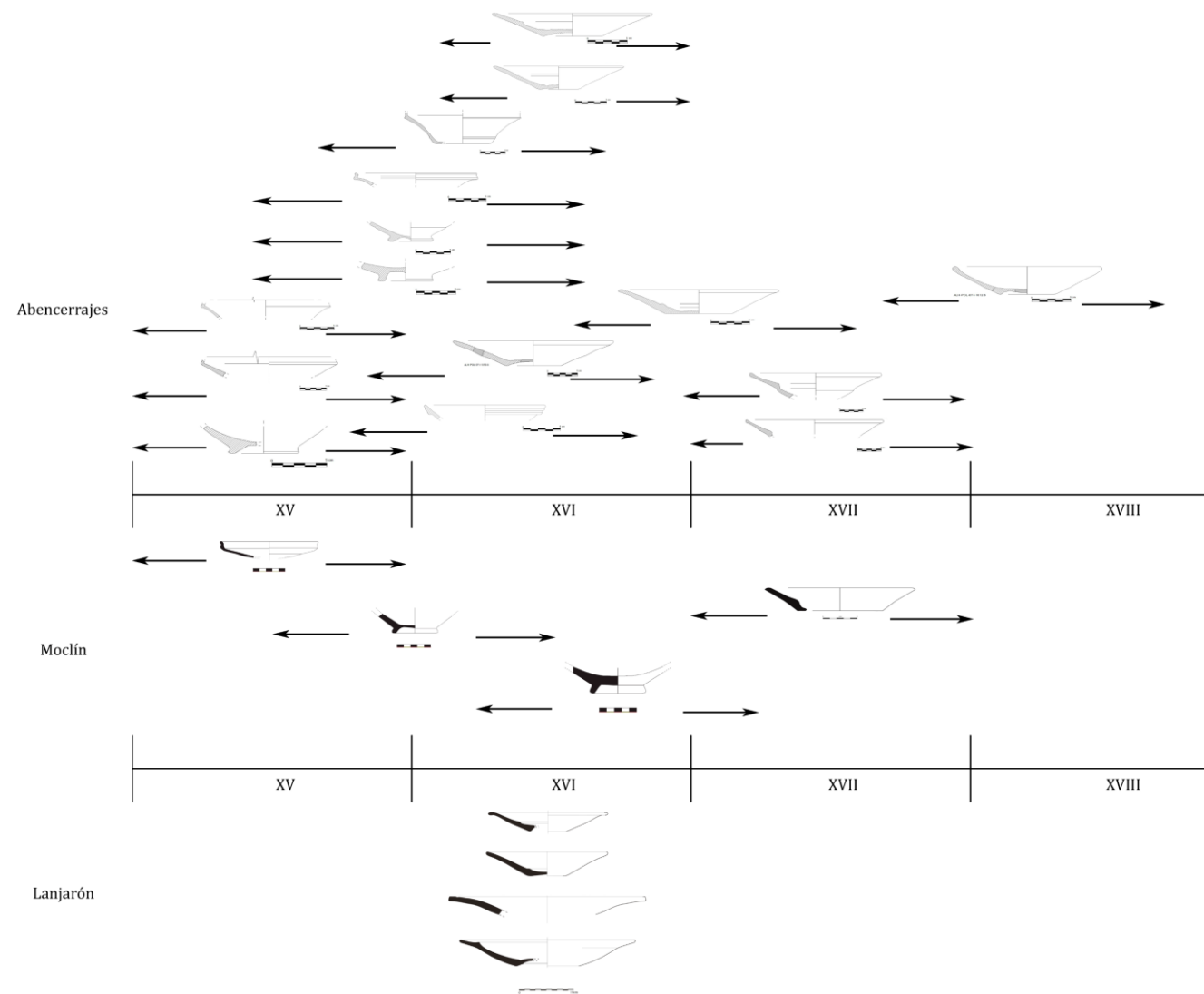
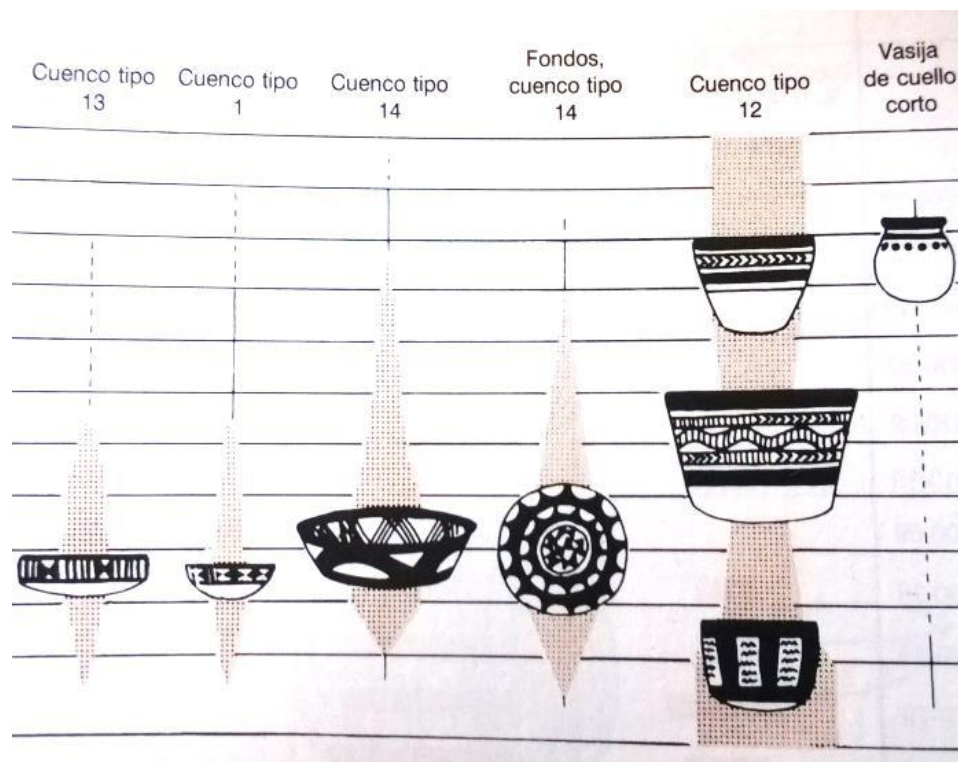



# Cerámica y comercio





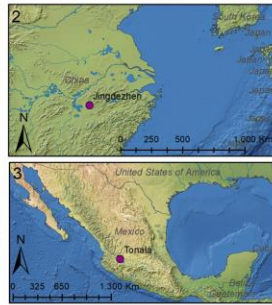
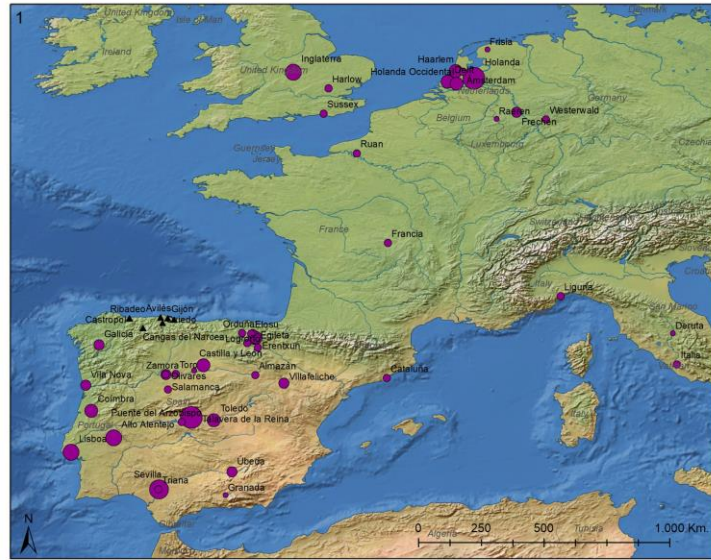

**Centros Importación S. XVII**

**Nº de piezas**

- 1
- 2 - 10
- 11 - 20
- 21 - 50
- 51 - 100
- 101 - 150
- 151 - 214

**Asturias S. XVII**

- ▲ Centros de consumo

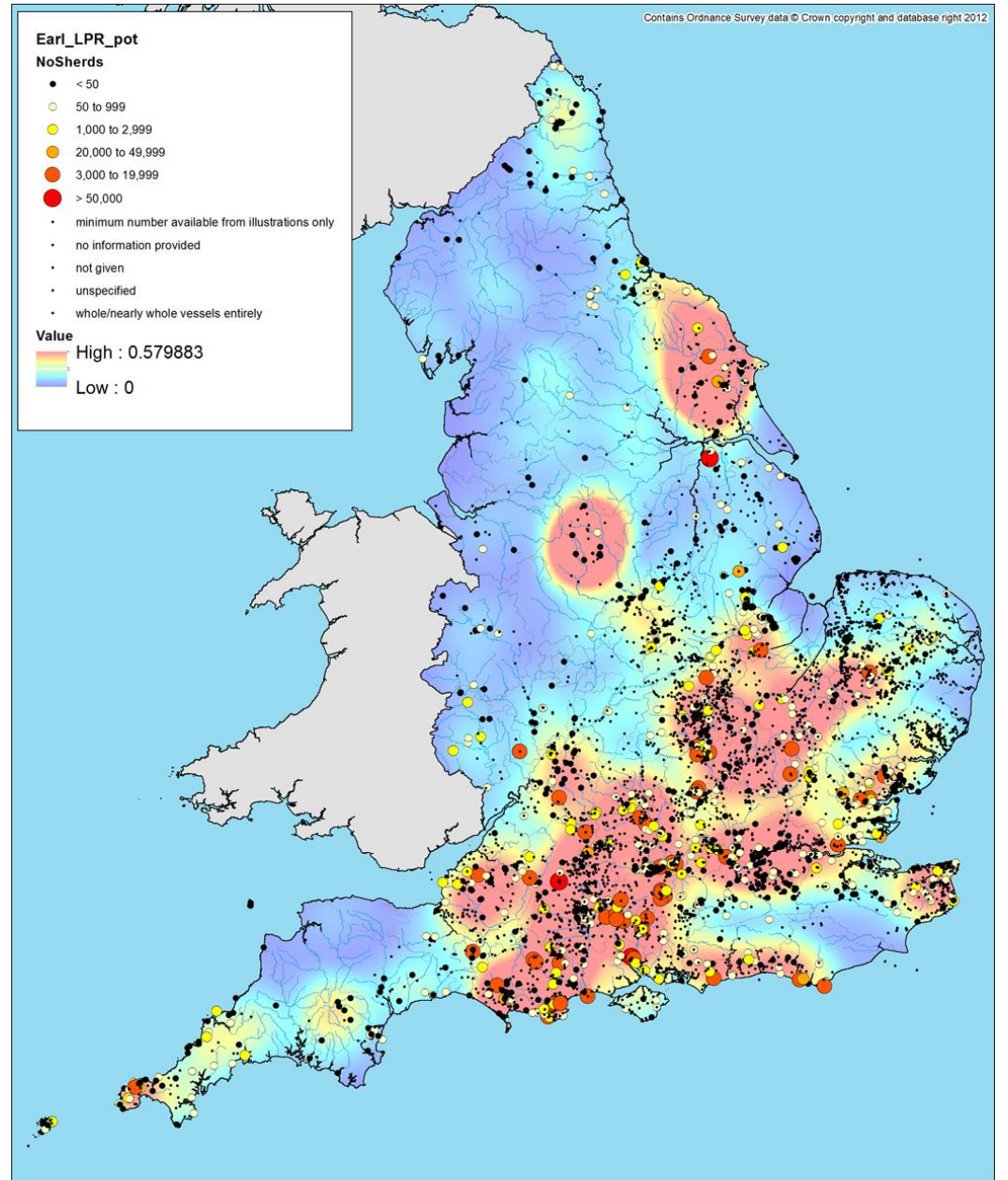

**Earl\_LPR\_pot**

**NoSherds**

- < 50
- 50 to 999
- 1,000 to 2,999
- 20,000 to 49,999
- 3,000 to 19,999
- > 50,000
- minimum number available from illustrations only
- no information provided
- not given
- unspecified
- whole/nearly whole vessels entirely

**Value**

High : 0.579883

Low : 0

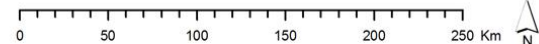



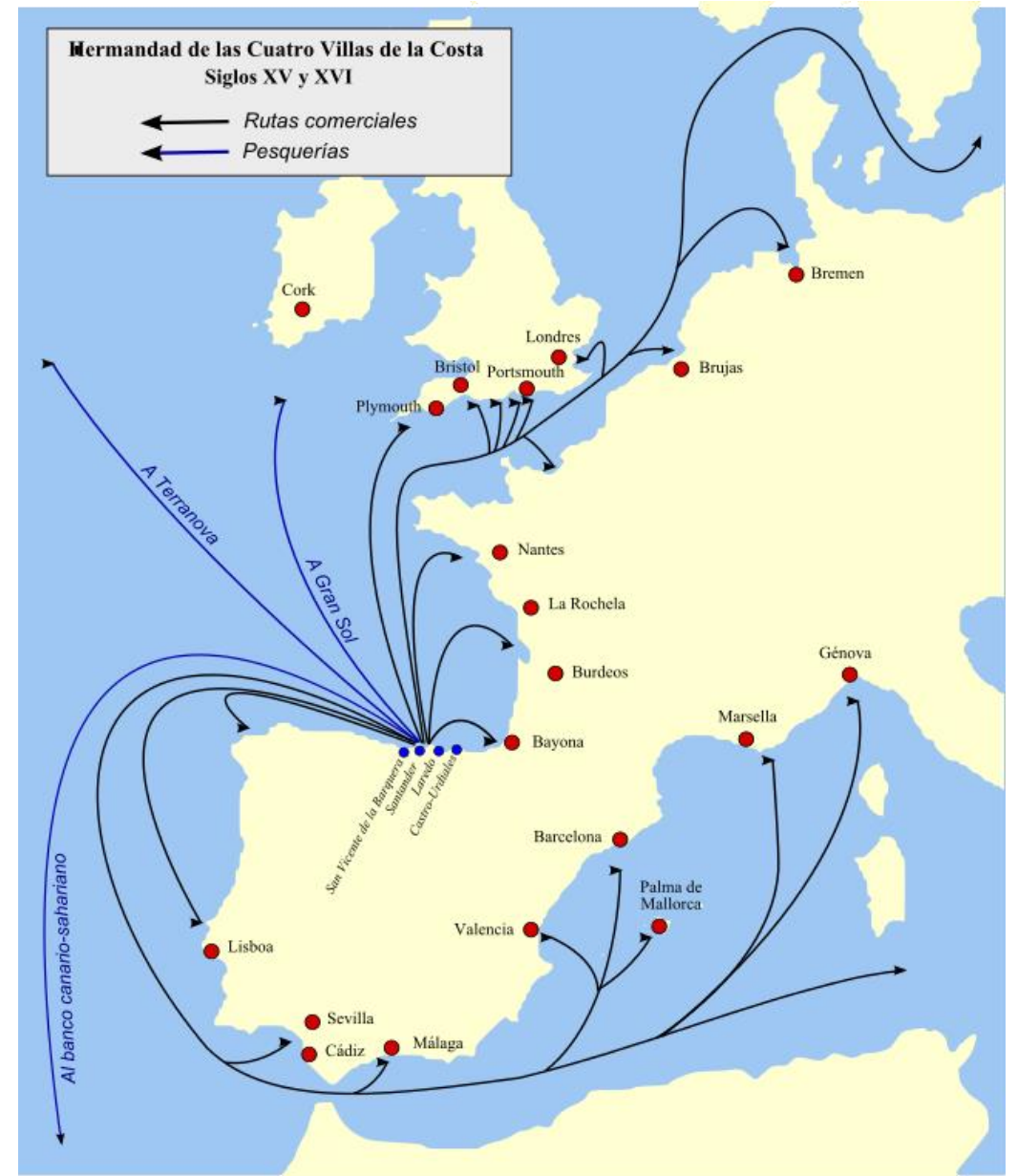



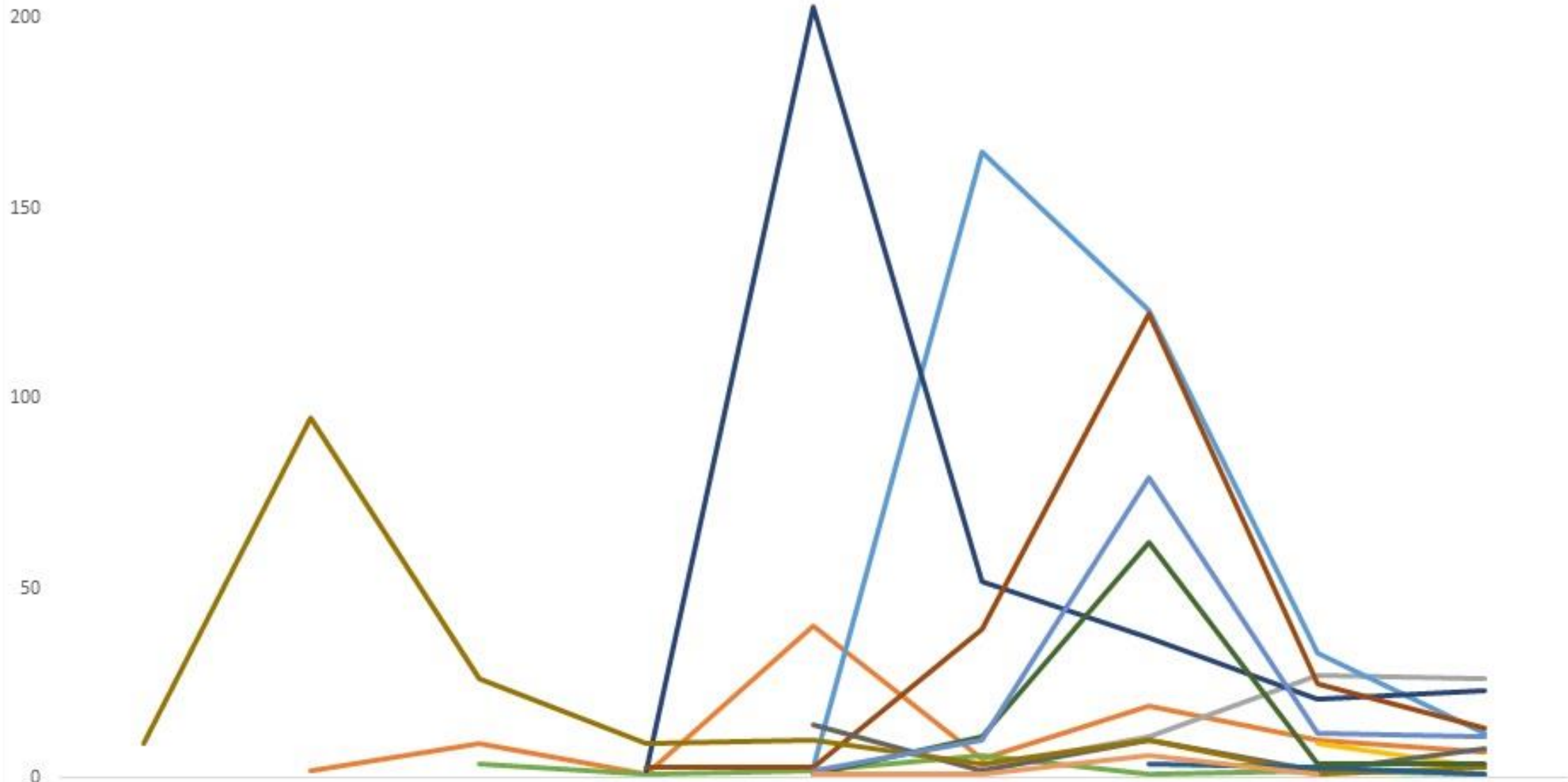

- Aragon
- Basque Country
- Castile and Leon
- Galicia
- Talavera de la Reina
- Valencia
- Seville
- Portugal
- Italy
- France
- Germany
- England
- Netherlands
- China
- Mexico

# Cerámica y función



ALH-POL-07-I-1028-5

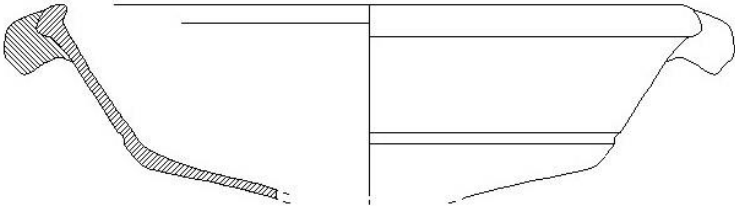

ALH-POL-07-I-1042-208

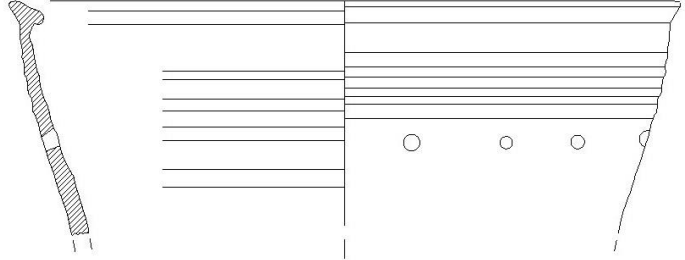



# Cerámica y *status*

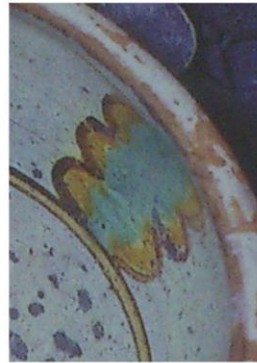



# ¿Cómo estudiar cerámica post-medieval?





**METODOLOGÍA**

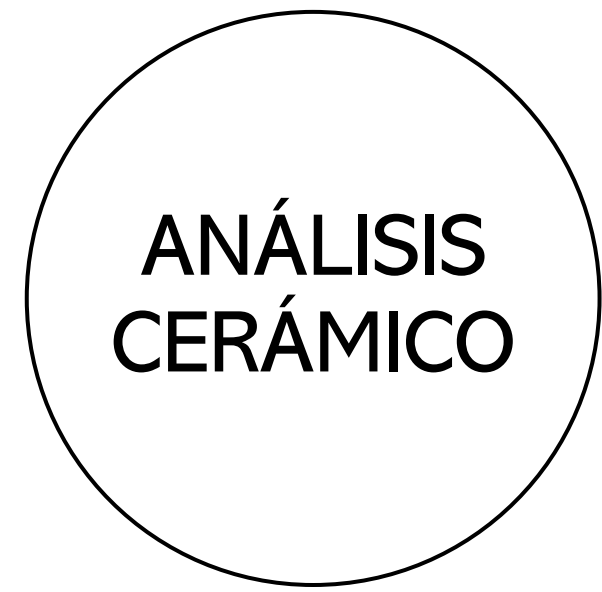







# Análisis Funcional Tipológico



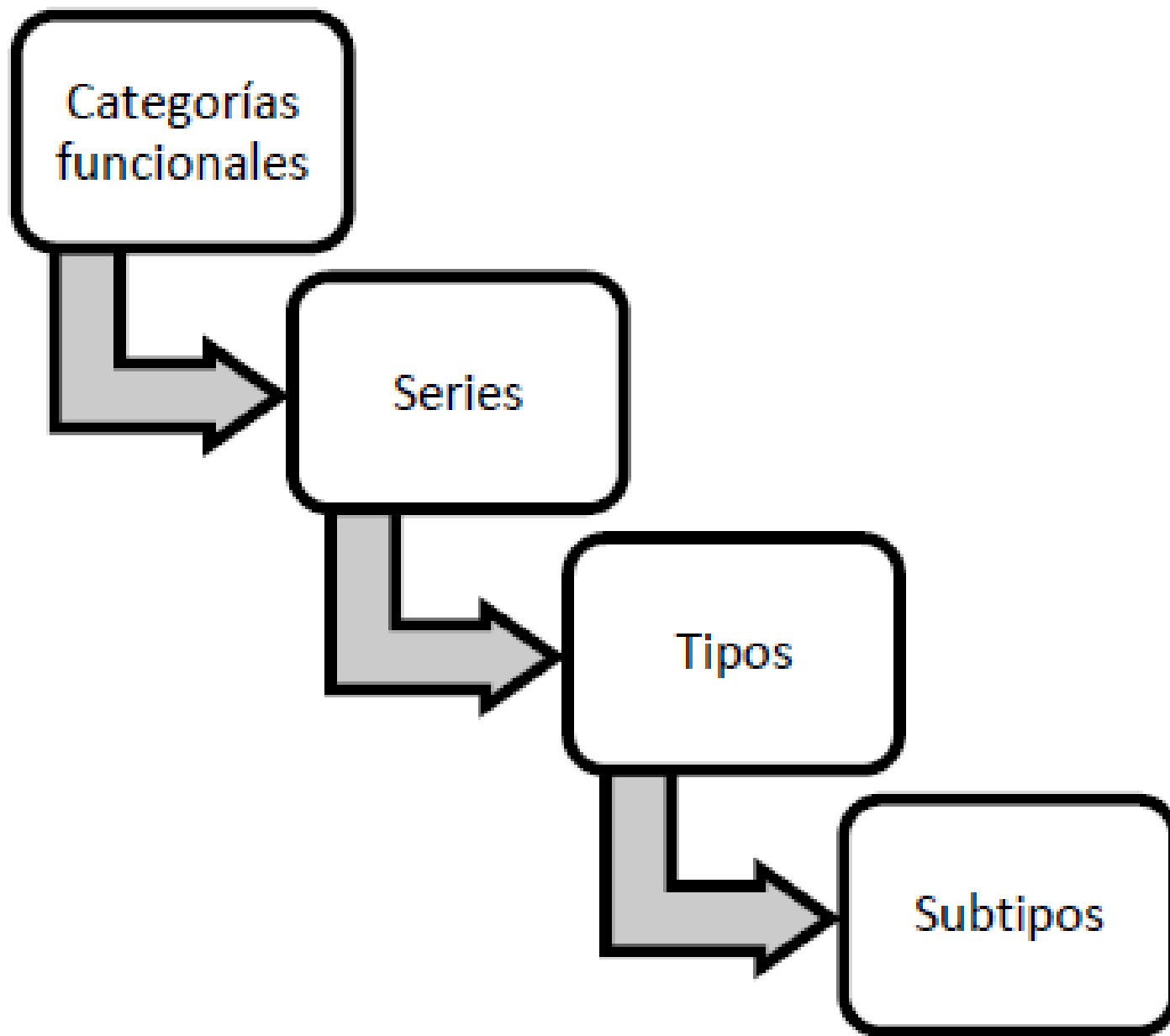





Preparación de alimentos	Consumo y servicio de alimentos sólidos o semilíquidos	Consumo y servicio de alimentos líquidos	Transporte y almacenamiento	Múltiples usos	Aseo e higiene	Consumo de tabaco	Uso arquitectónico	Iluminación	Uso devocional	Uso lúdico	Uso decorativo	Otros usos
Anafre	Almofia	Botella	Aceitera	Cubilete	Bacín	Pipa	Azulejo	Candelero	Benditera	Miniatura	Maceta	Tintero
Cazuela	Cuenco	Copa	Albarelo	Especiero								
Colador	Escudilla	Jarrita/o	Bote	Lebrillo								
Olla	Fuente	Jícara	Botijuela	Salero								
Puchero	Platito	Redoma	Caneco									
Quesera	Plato	Tapadera	Cántaro									
Tapadera		Vaso	Jarra/o									
			Orza									
			Tonelete									

### FORMAS ABIERTAS

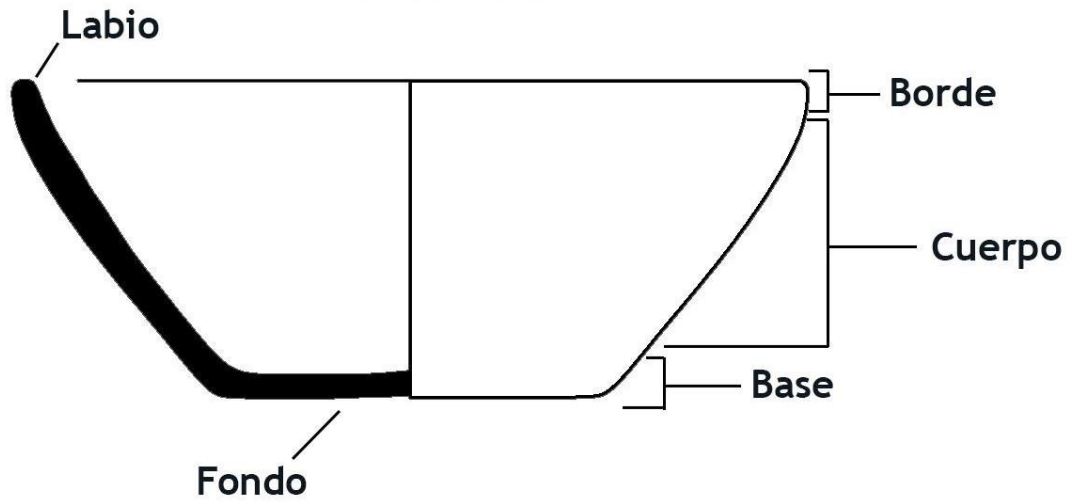

### FORMAS CERRADAS

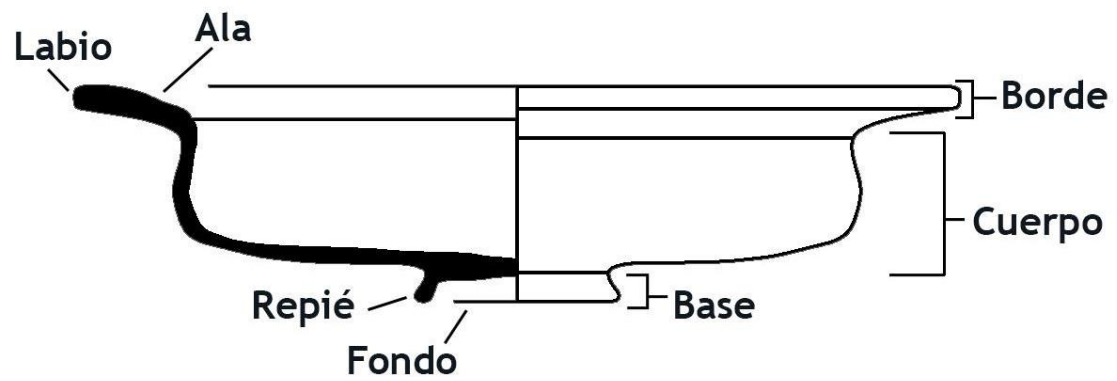
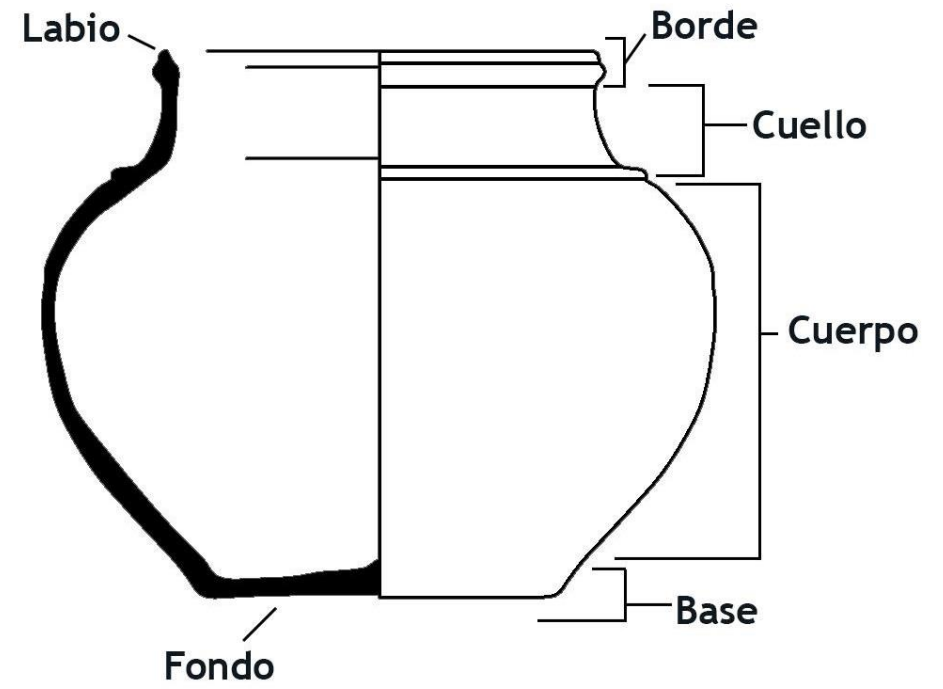

Ertz motak. Tipos de bordes.



Jarraituak.  
Continuos



Kanpoko aldera irtena.  
Exvasado



Barruko aldera sartua.  
Envasado

Ezpain motak. Tipos de labios



Biribildua.  
Redondeado



Loditu  
biribildua.  
Engrosado  
redondeado



Molduratu  
biribildua.  
Moldurado  
redondeado



Triangeluarra.  
Triangular



Triangeluar  
loditua.  
Engrosado  
triangular



Molduratu  
triangeluarra.  
Moldurado  
triangular



Ertz molduratu triangeluarra  
eta ezpain biribildua.  
Borde moldurado triangular  
y labio redondeado



Alakatua.  
Biselado



Laua.  
Plano



Zorrotza.  
Apuntado



Molduratu  
zorrotza.  
Moldurado  
apuntado



Betile iburako ertza  
eta ezpain biribildua.  
Borde apestañado  
y labio redondeado



Betile iburako ertzak eta  
ezpain zorrotza.  
Bordes apestañados y  
labio apuntado

Gider motak. Tipos de asas



Xingola iburakoa.  
De cinta



Erdialdeko sakonunearekin.  
Con depresión central



Albo lodituekin.  
Con engrosamientos laterales



Erdialde lodituekin.  
Con nervio central



Eraztun iburakoa.  
Anular

Hondo motak. Tipos de bases



Laua.  
Plana



Ahurra.  
Cóncava



Oin lau trinkoarekin.  
Con pie plano macizo

Caro, A. (2002). *Ensayo sobre cerámica en arqueología*. Sevilla: Agrija Ediciones.

Solaun Bustinza, J. L. (2005). *La cerámica medieval en el País Vasco (Siglos VIII-XIII)*. Victoria-Gasteiz: Servicio Central de Publicaciones del Gobierno Vasco.



Abencerrajes

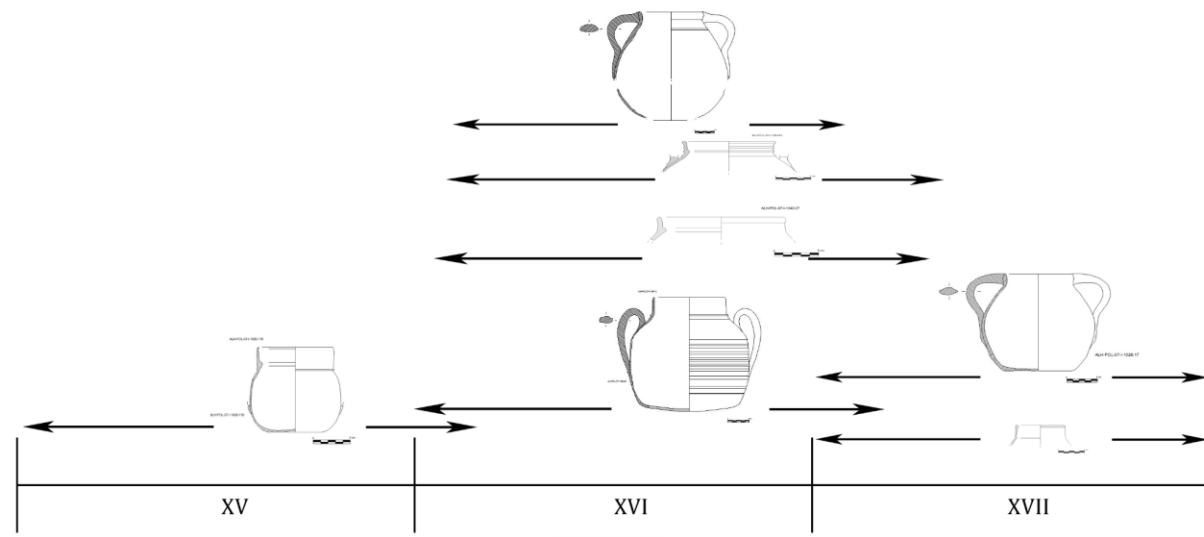

Moclín

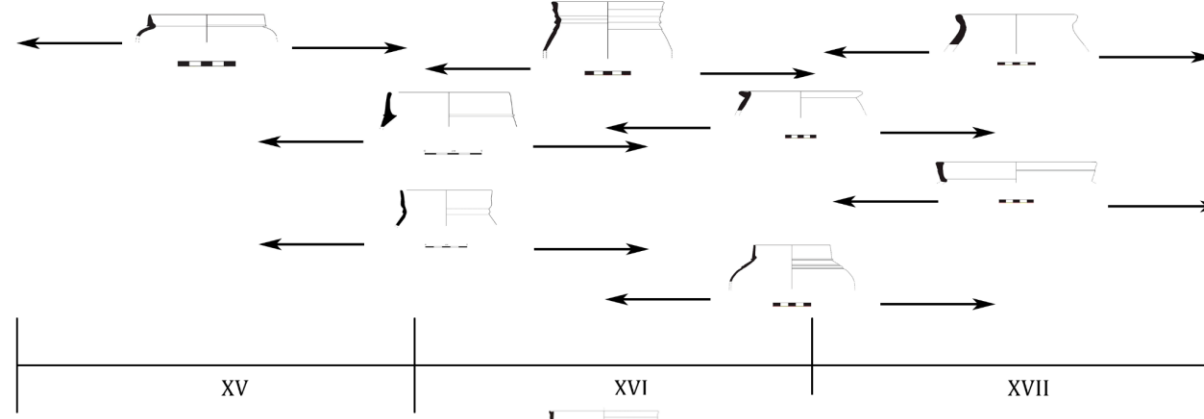

Lanjarón



Abencerrajes

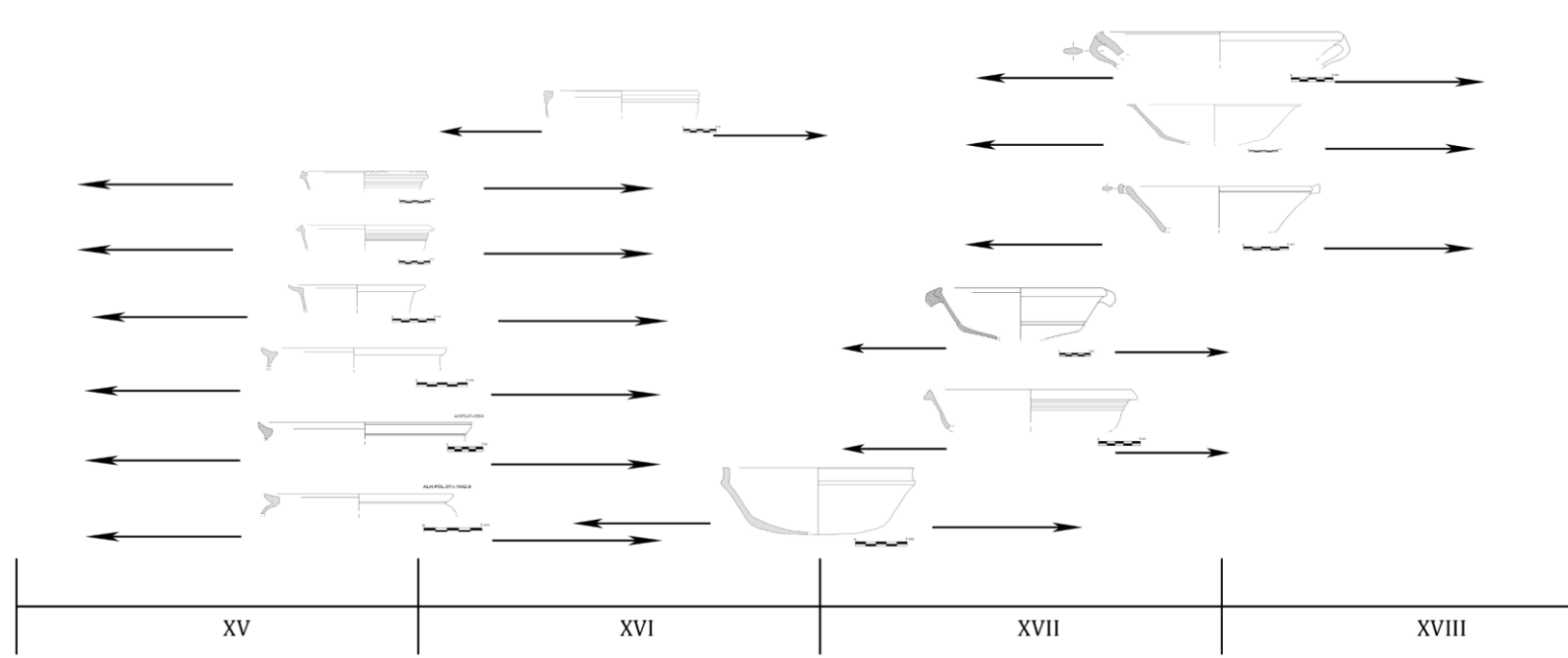

Moclín

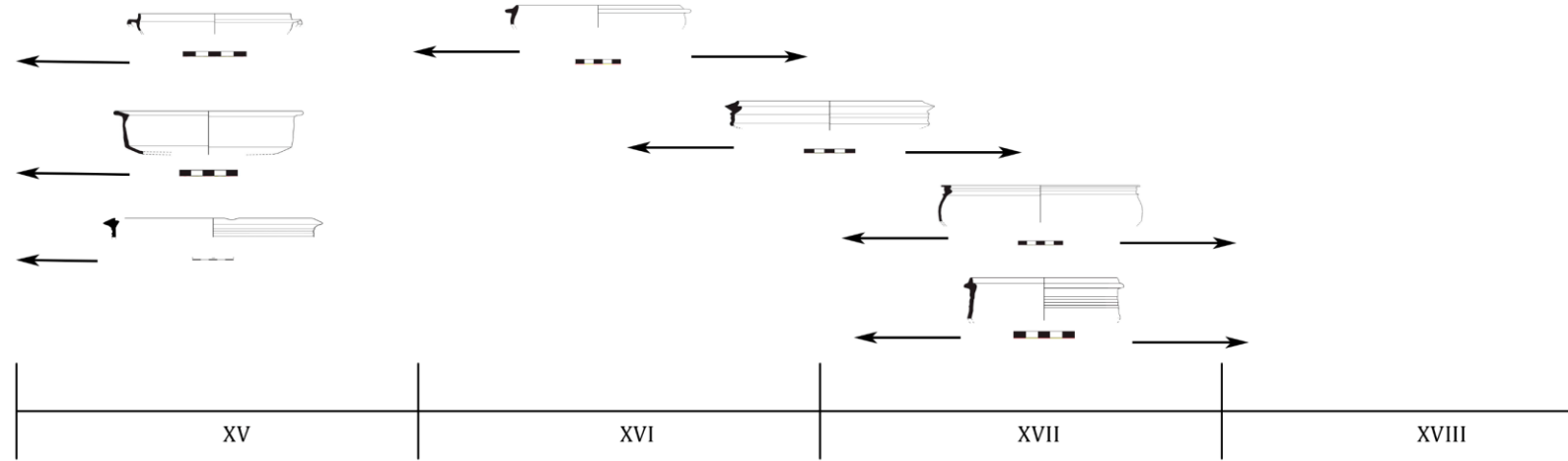

Lanjarón

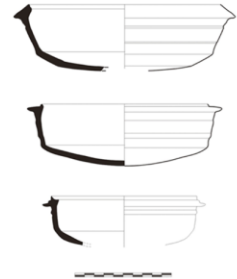

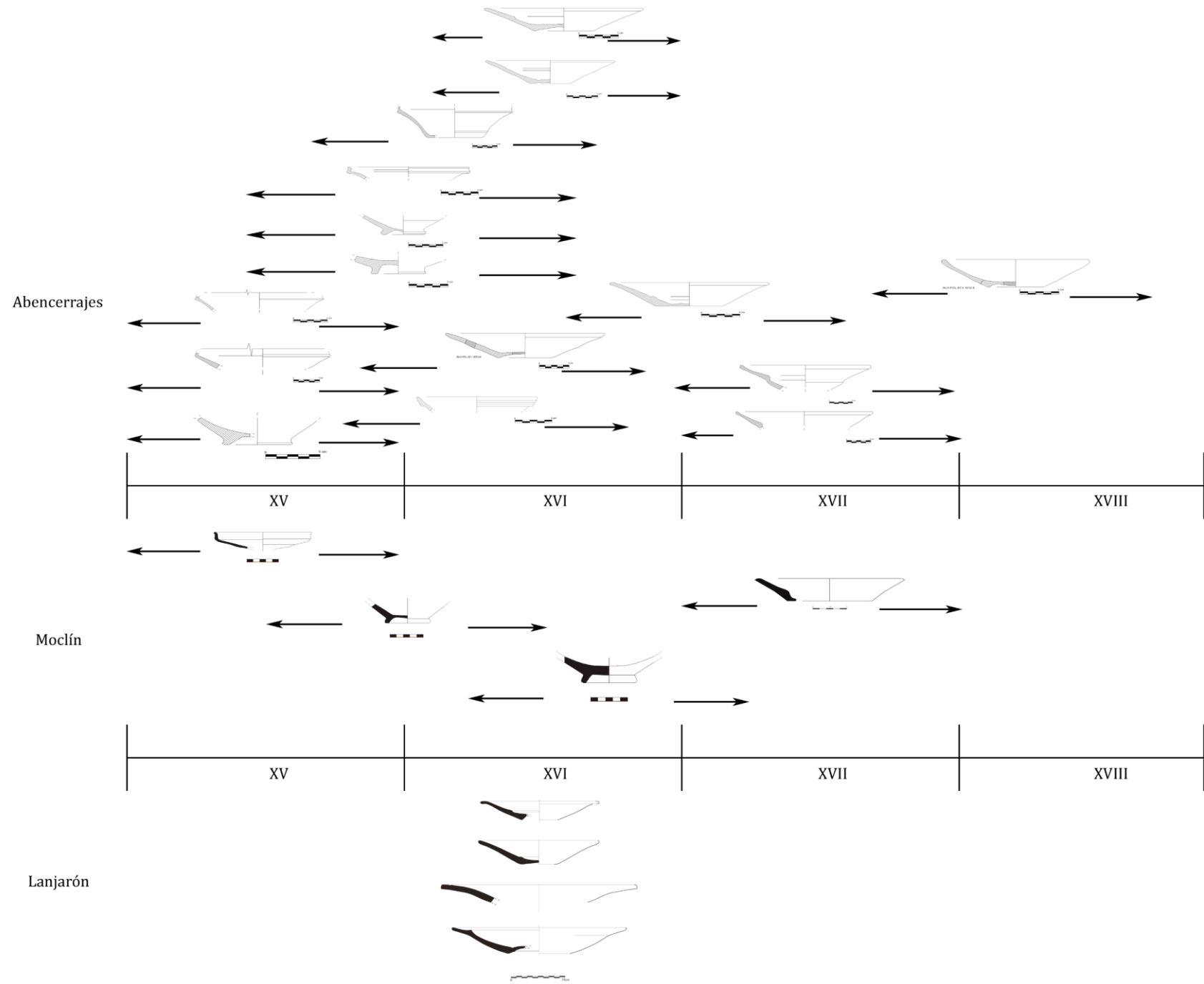



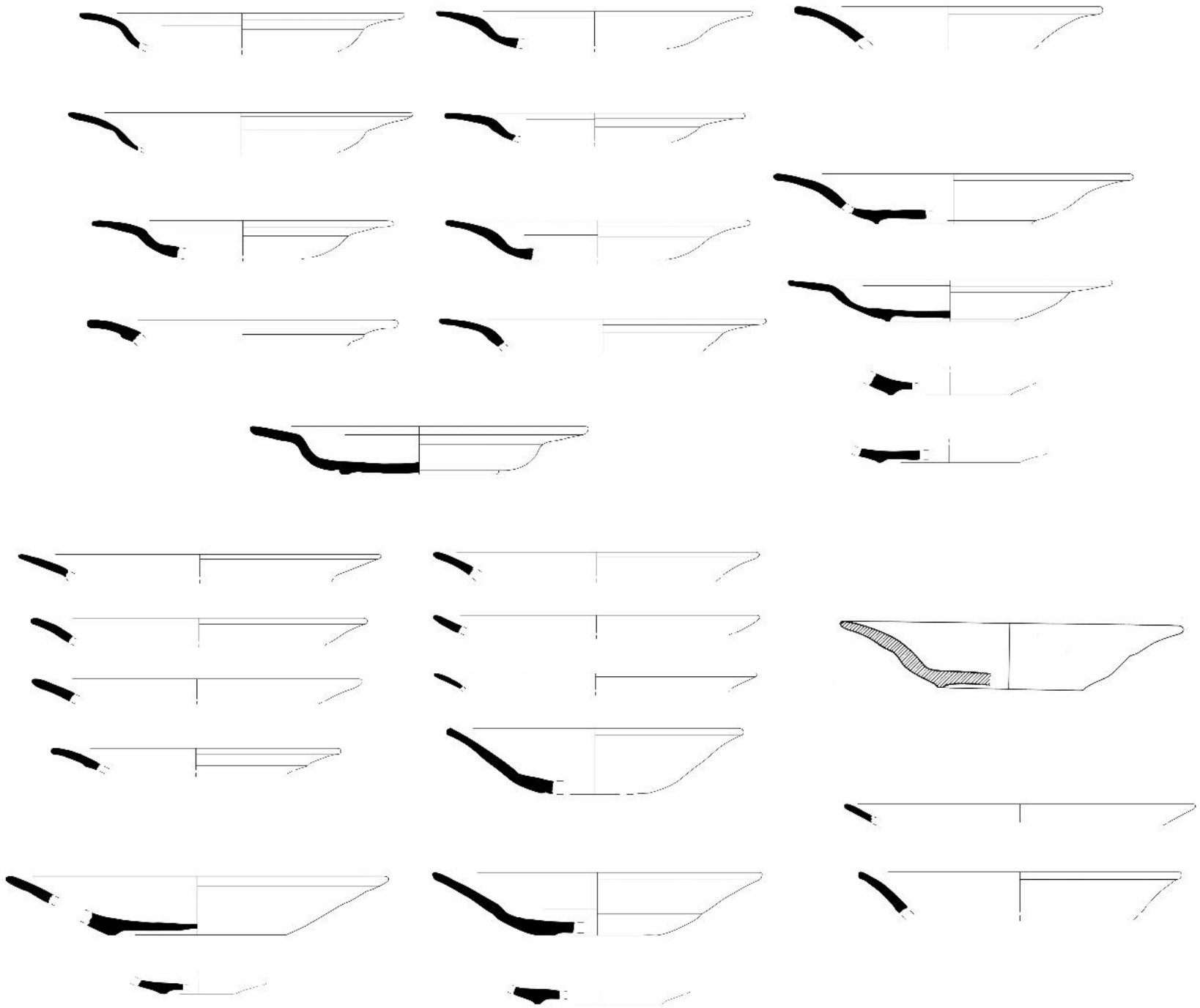

0 5 cm

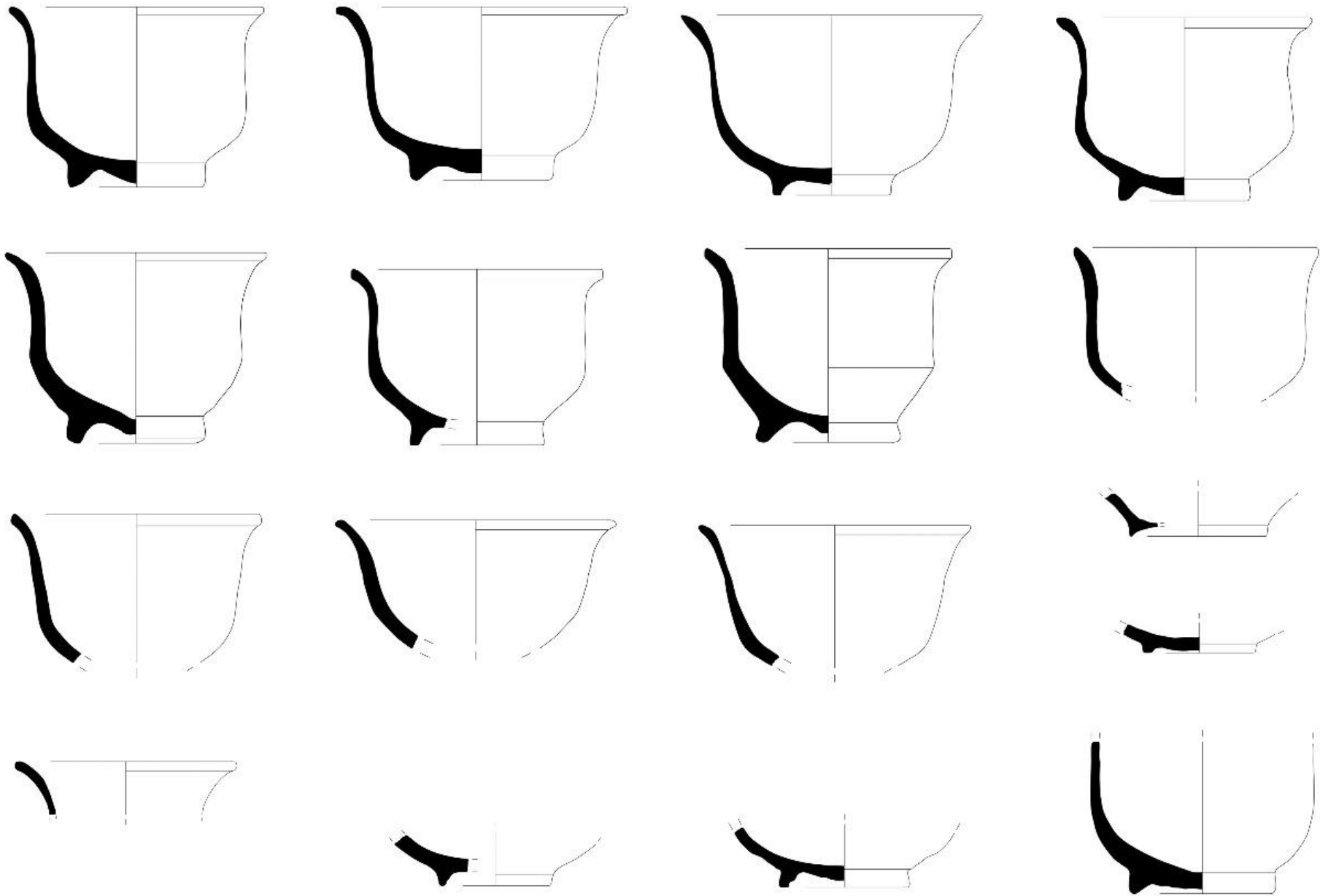

0 5 cm





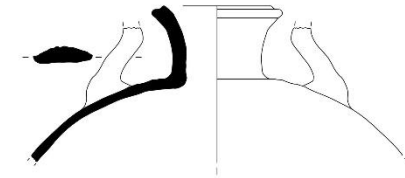
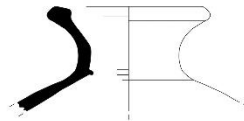
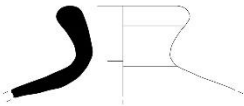
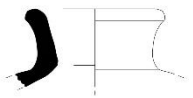
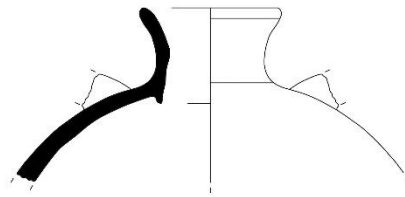
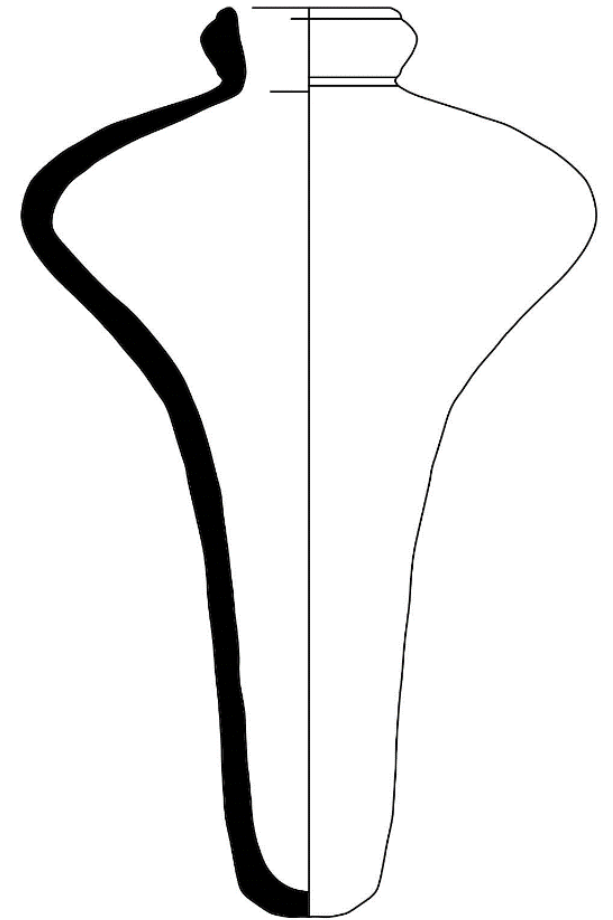
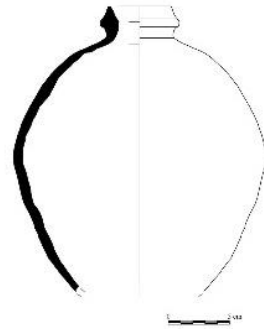
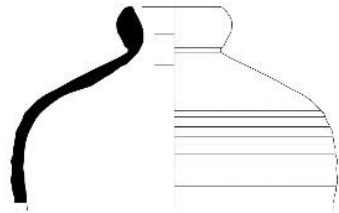
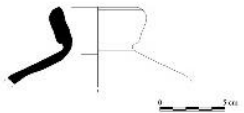
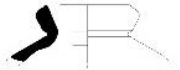
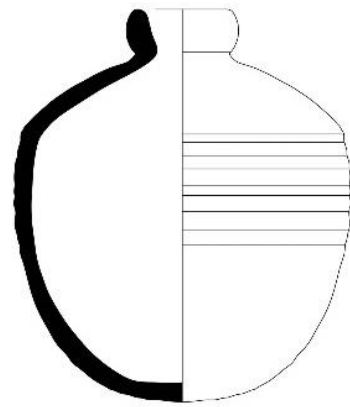
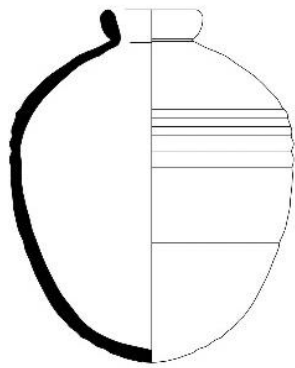
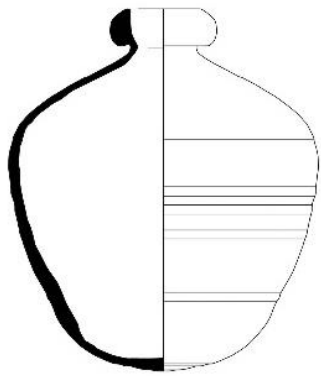
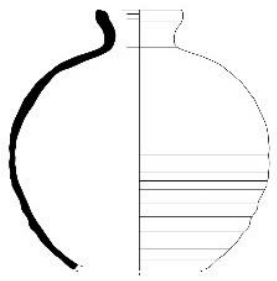

0 5 cm

0 5 cm

# Análisis Tecnológico



# Ciclo produttivo

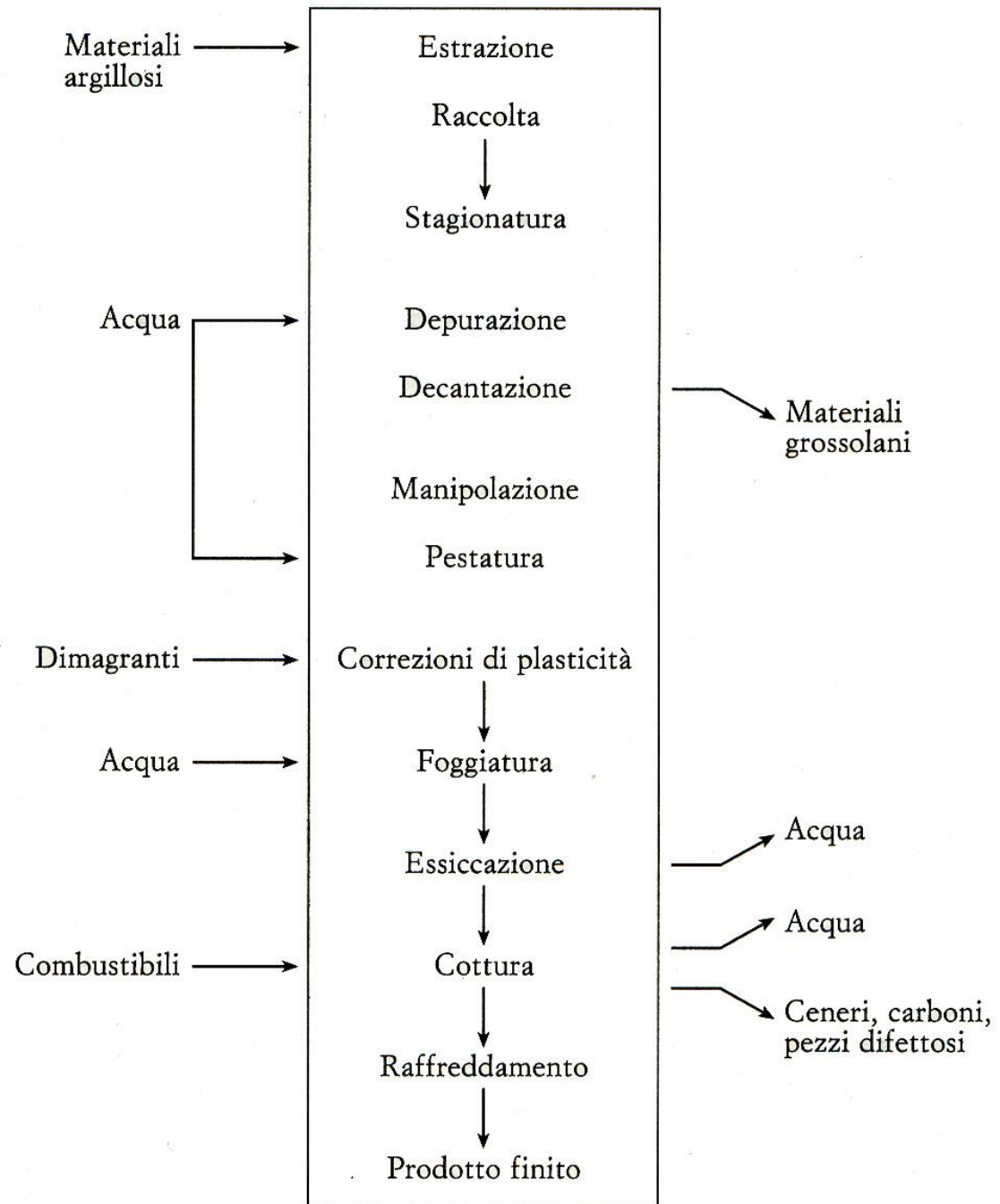

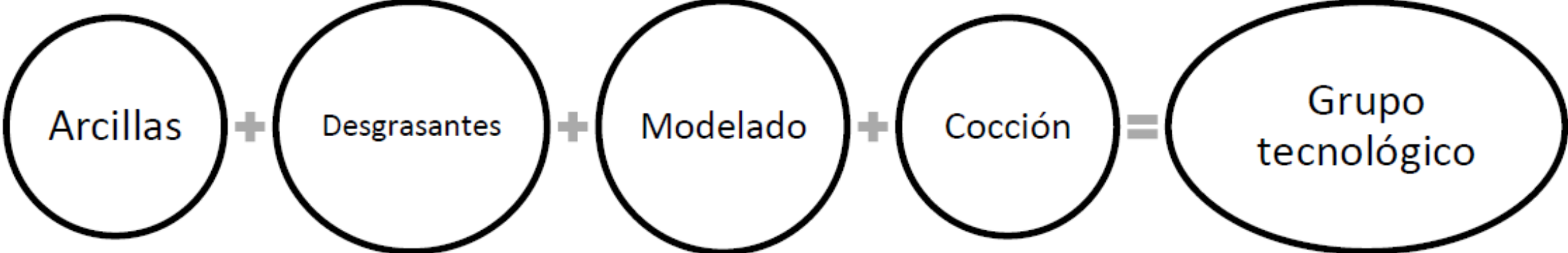



# Principales Grupos Tecnológicos



## *Cerámica vidriada*

- Sinónimo: barniz, vedrío. Glazed.
- Cubierta plúmbea que se obtiene mezclando plomo, arena y sal que hay que fundir y luego moler.
- Se trata de una cubierta más o menos translúcida que puede acompañarse con otros óxidos.
- Se aplica antes de la primera cocción.
- Temperaturas que oscilaron entre los 950-1.000°C



*Sevillana Verde lisa - Lebrillo I*

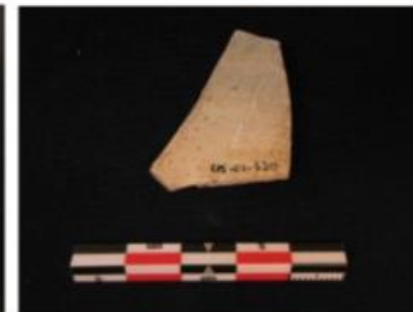
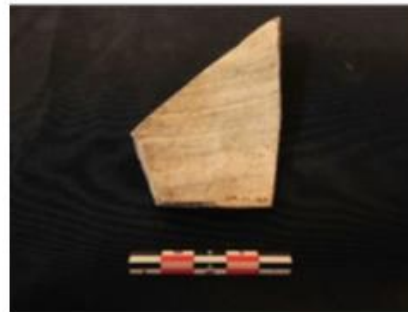
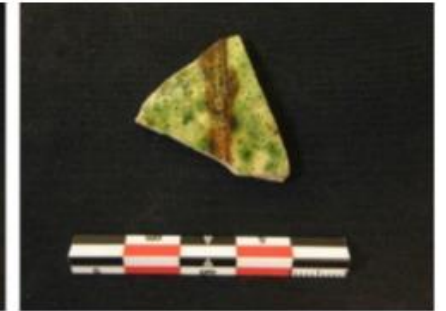
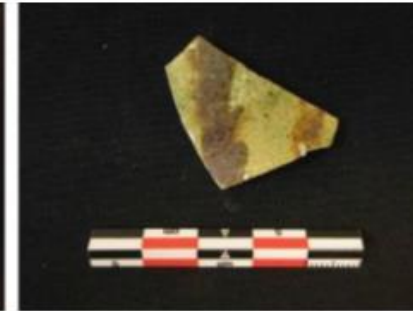
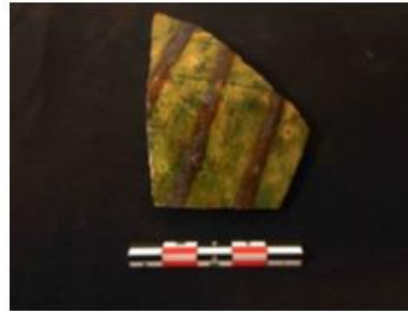

*Francesa del Centro-Suroeste (Saintonge) - Jarrita/o VII*

## *Cerámica esmaltada*

- Sinónimo: loza, cubierta estannífera, esmalte. *Tin-glazed*
- Cubierta de color blanco, obtenido fundiendo sílice con sal y plomo más estaño.
- Cubierta opaca, de color blanco, que se aplica a las piezas.
- Se aplica generalmente en una segunda cocción.
- El horno habría alcanzado unas temperaturas en torno a los 900-1.200°C

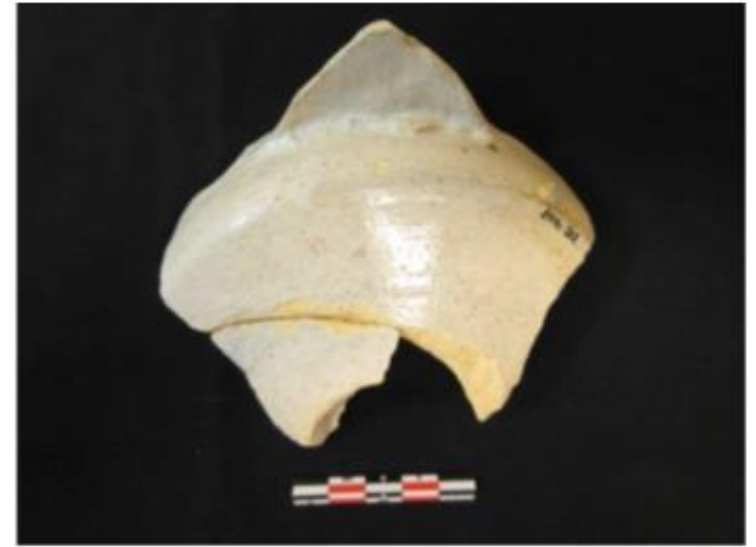

*Sevillana Azul y morada - Escudilla II*

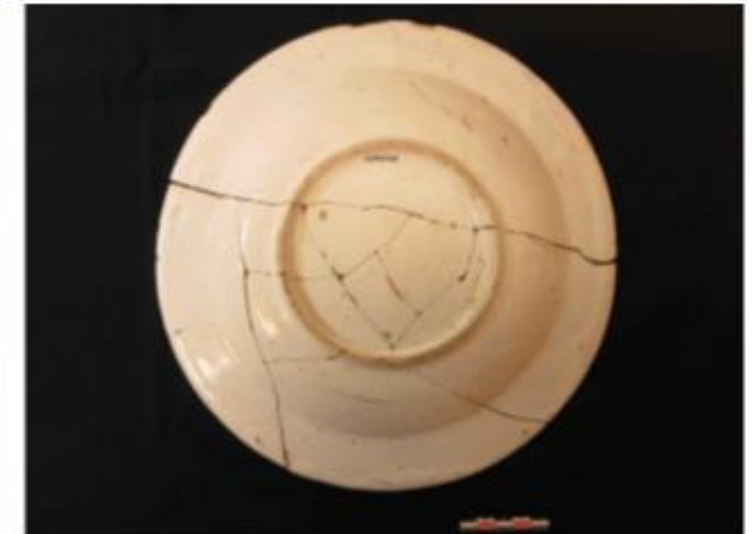

*Talaverana Tricolor - Fuente I*

# Gres

- Sinónimo: vidriado a la sal. *Stoneware*.
- La cubierta se logra al volatilizar la sal común dentro del horno durante la cocción.
- Esto a veces da como resultado una textura que se compara con la cáscara de naranja.
- Este proceso solo es posible en hornos con una temperatura superior a 1.100°C.



*Alemana Gres - Jarra IIIA Westerwald*





# Porcelana

- Se compone de los siguientes materiales: caolín (50-55%), cuarzo y feldespato.
- Se cuece a una temperatura alrededor de 1.800 °C.

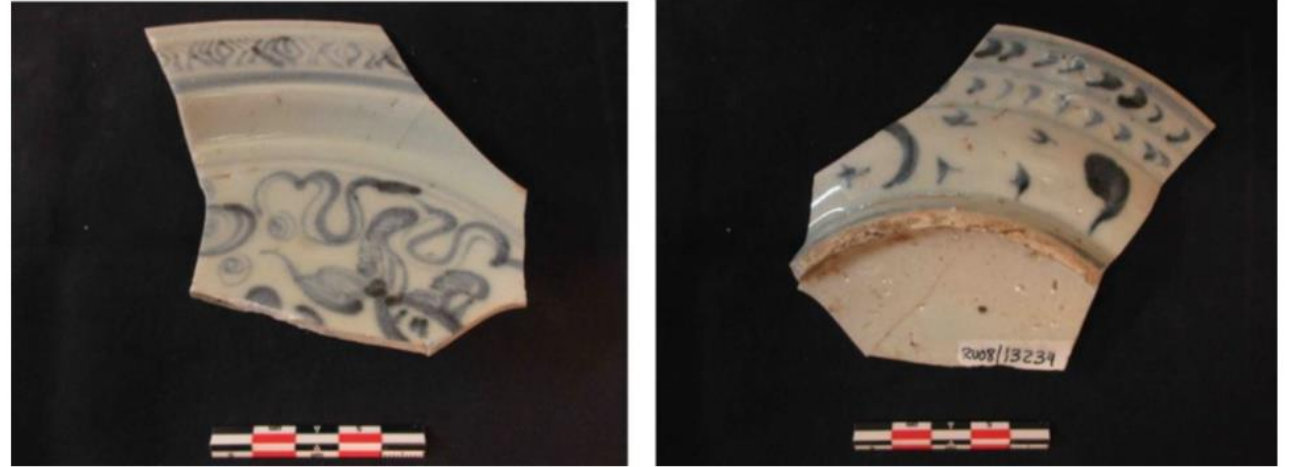

*China - Plato I*



# Principales Producciones Post-medievales





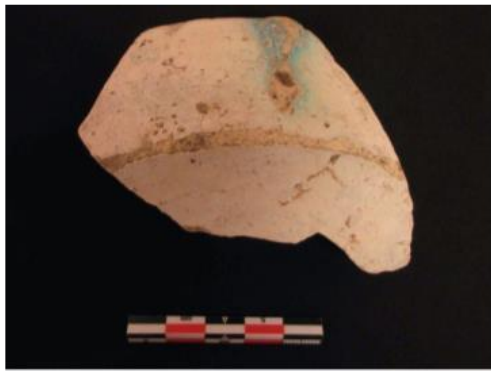

*Sevillana Blanca de apéndices verdes - Escudilla I*



*Sevillana Verde lisa - Lebrillo I*

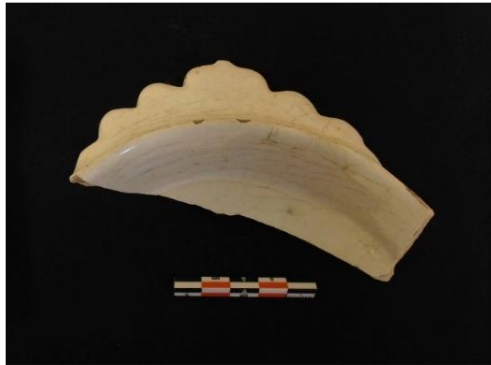

*Sevillana Blanca lisa - Cuenco II*

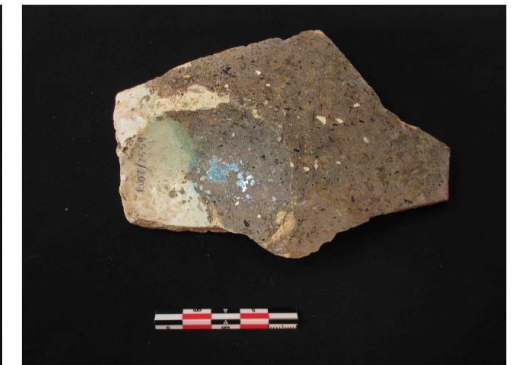
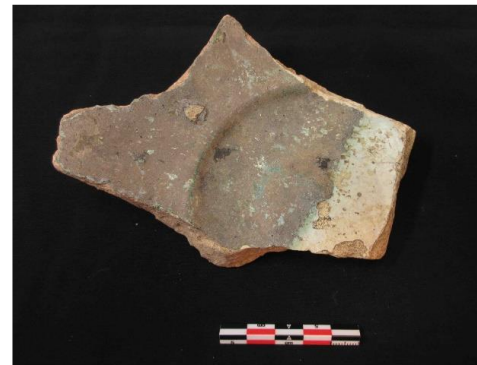

*Sevillana Azul y morada - Escudilla II*

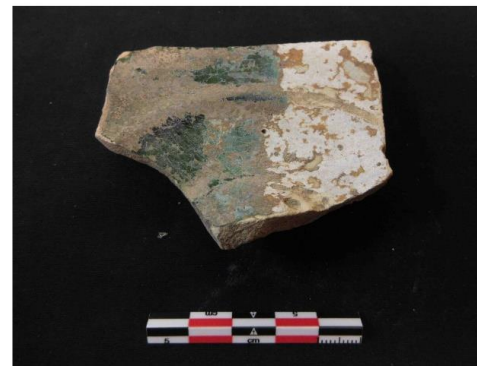

*Sevillana Blanca y verde de mitades - Plato I*

*Sevillana Verde lisa - Lebrillo II*

- Cronología pieza: 1500-1599
- Cronología contexto: XVI
- Centro de proveniencia: Sevilla



Acabado y decoración de *Sevillana Verde lisa - Lebrillo II*. En imagen, pieza hallada en el palacio de Valdecarzana (Avilés).

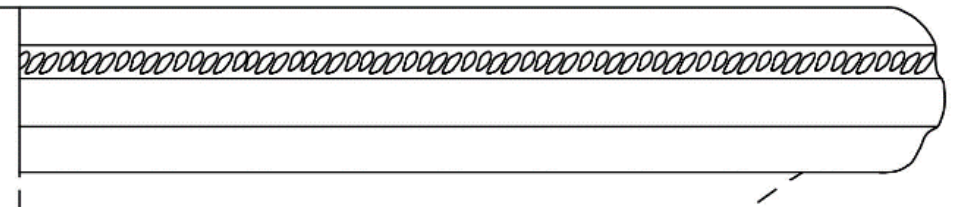
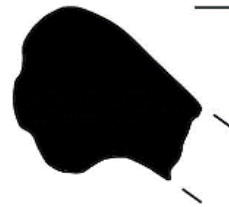

0 5 cm



# Sevillana Botijuela I



- Cronología pieza: 1550-1799
- Cronología contexto: XVIII
- Centro de proveniencia: Sevilla

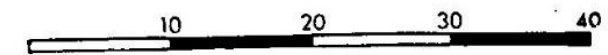
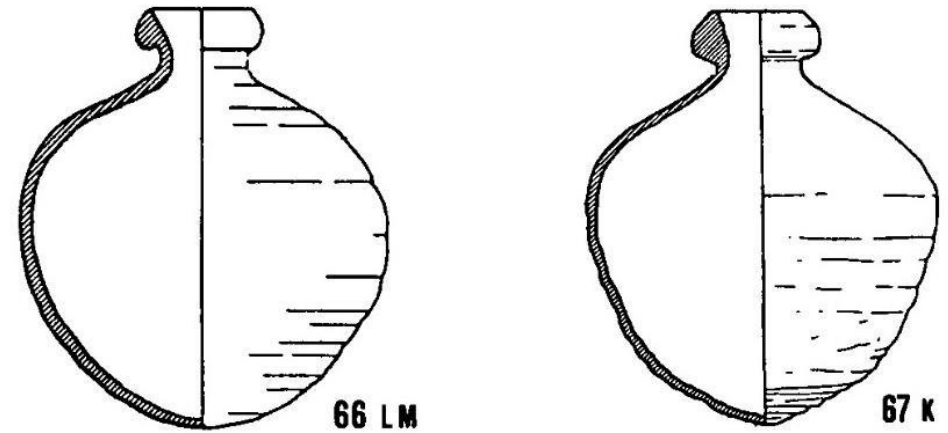
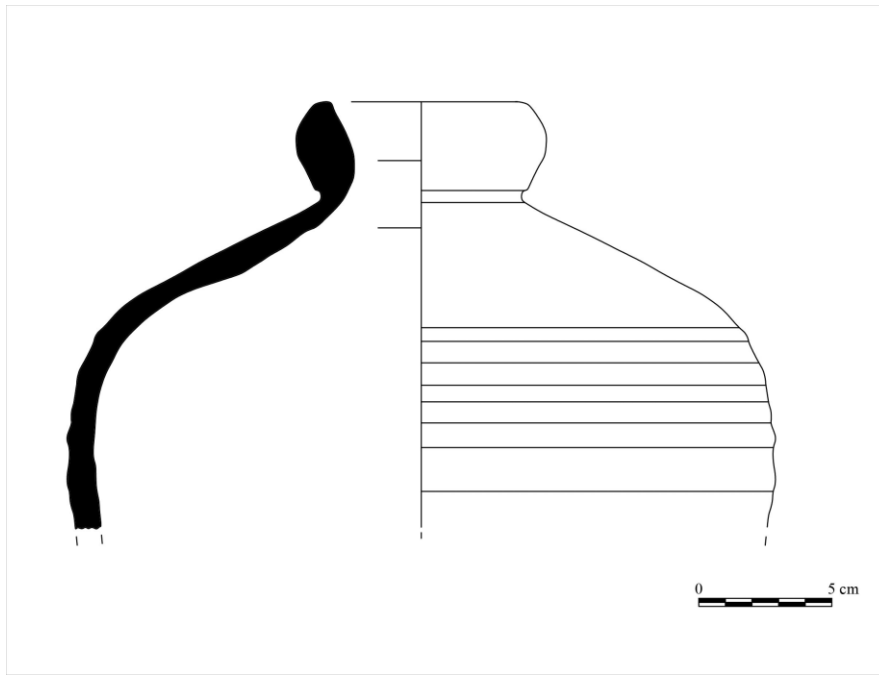

*Botijuela Tipo B*, Sevilla, 1550-1800 (Amores Carredano & Chisvert Jiménez, 1993, p. 309).



*Talaverana Tricolor - Fuente I*



*Talaverana Tricolor - Fuente III*



*Talaverana Tricolor - Redoma I*



*Talaverana Helechos- Plato IA aves*

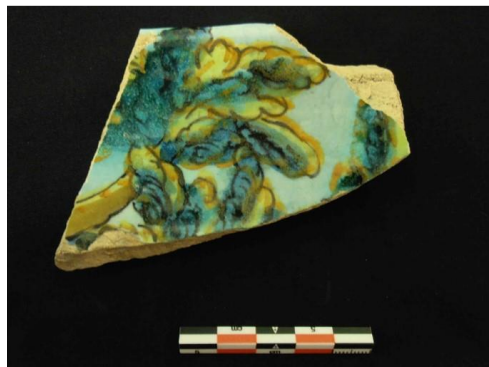

*Polícroma Talaverana - Cuenco II. En*



*Polícroma Talaverana - Jícara I*



## *Talaverana Tricolor - Fuente III*

- Cronología pieza: 1600-1699
- Cronología contexto: XVII
- Centro de proveniencia: Talavera de la Reina

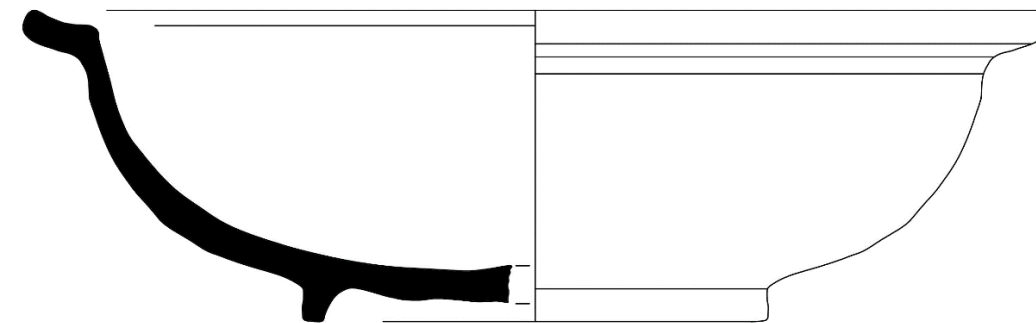

0 5 cm



Acabado y decoración de *Talaverana Tricolor - Fuente III*. En imagen, pieza procedente de la Catedral de Oviedo.



## *Talaverana Tricolor - Tintero I*

- Cronología pieza: 1600-1650
- Cronología contexto: XVII
- Centro de proveniencia: Talavera de la Reina

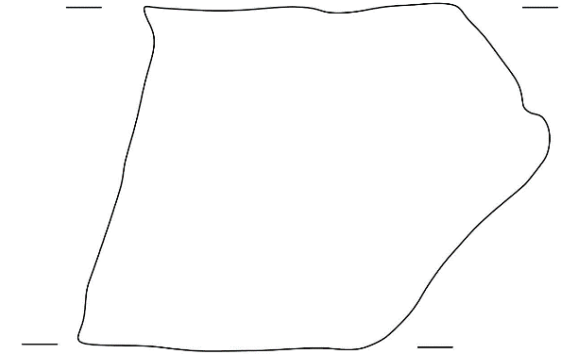
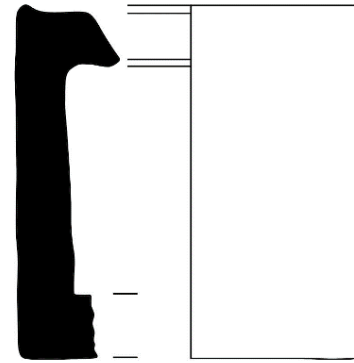

Decoración y acabado de *Talaverana Tricolor - Tintero I*. En imagen, pieza hallada en la Catedral de Oviedo.



## *Talaverana Tricolor - Redoma I*

- Cronología pieza: 1652
- Cronología contexto: XVII
- Centro de proveniencia: Talavera de la Reina

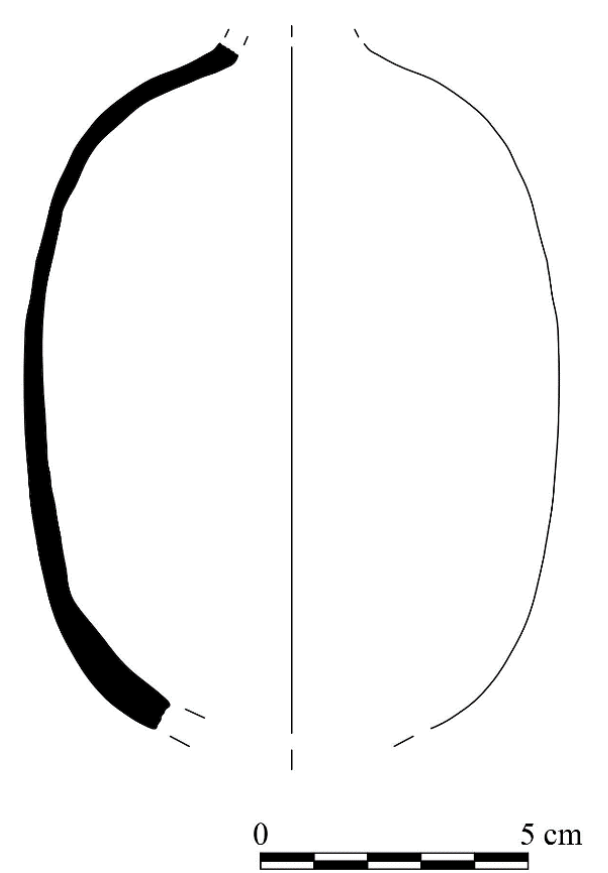

Decoración y acabado de *Talaverana Tricolor - Redoma I*. En imagen, pieza hallada en la Catedral de Oviedo.

## *Aragonesa Talaverana - Cuenco I tricolor*

- Cronología pieza: 1600-1699
- Cronología contexto: XVII
- Centro de proveniencia: Aragón - Villafeliche

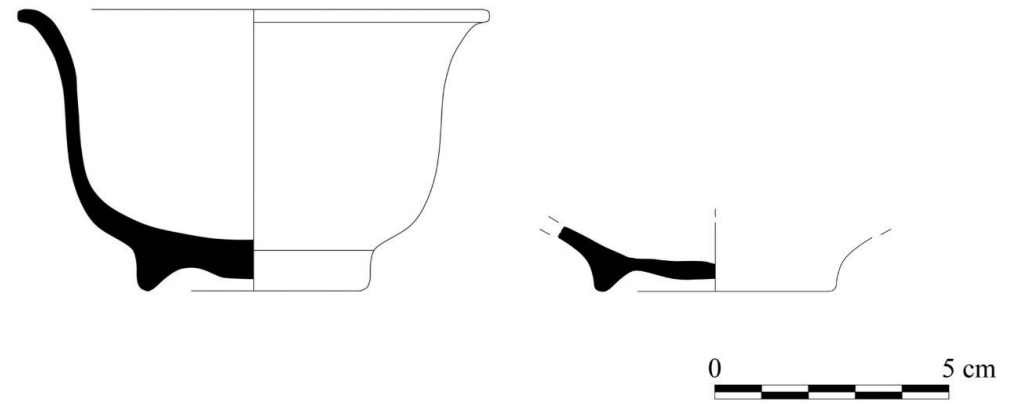

Acabado y decoración de *Aragonesa Talaverana - Cuenco I tricolor*.  
En imagen piezas procedentes de la Catedral.

## *Riojana Talaverana - Cuenco I tricolor*

- Cronología pieza: 1680-1699
- Cronología contexto: XVII
- Centro de proveniencia: La Rioja - Logroño

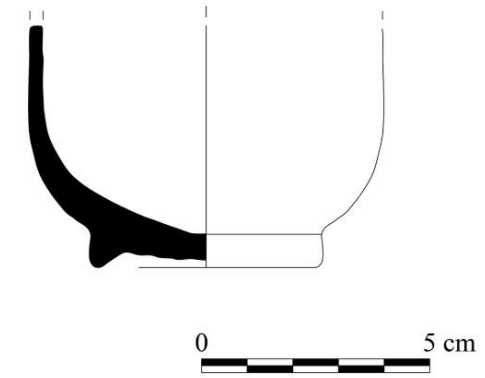
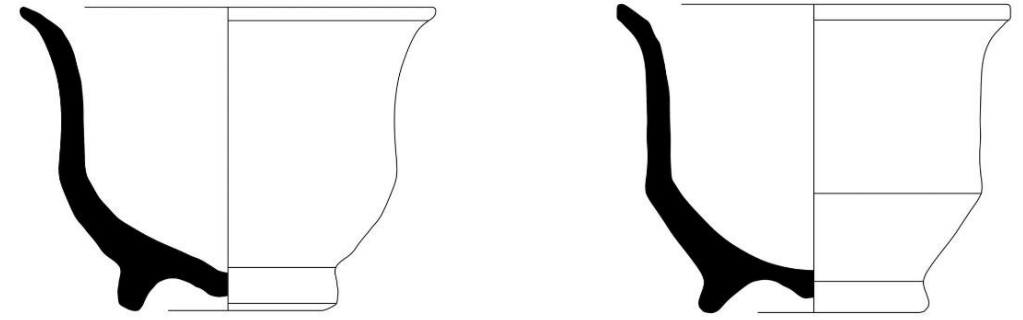

Acabado y decoración de *Riojana Talaverana - Cuenco I tricolor*. En imagen piezas procedentes de la Catedral de Oviedo.

*Talaverana Helechos - Plato IIA aves*



- Cronología pieza: 1620-1725
- Cronología contexto: XVII-XVIII
- Centro de proveniencia: Talavera de la Reina

Acabado y decoración *Talaverana Helechos - Plato IIA aves*. En imagen, pieza procedente de la Catedral de Oviedo.

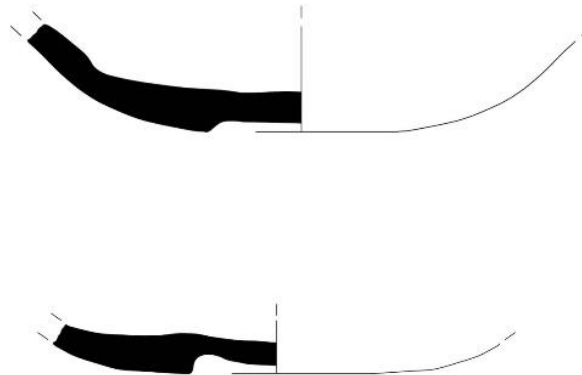
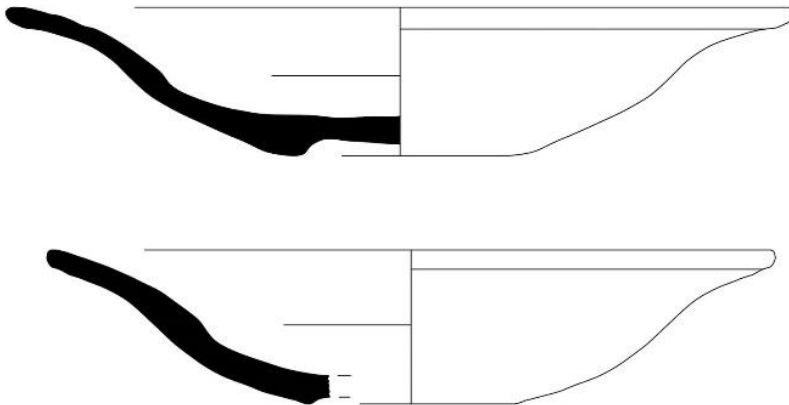

0 5 cm



*Talaverana Helechos - Plato IA aves*



- Cronología pieza: 1620-1725
- Cronología contexto: XVII-XVIII
- Centro de proveniencia: Talavera de la Reina

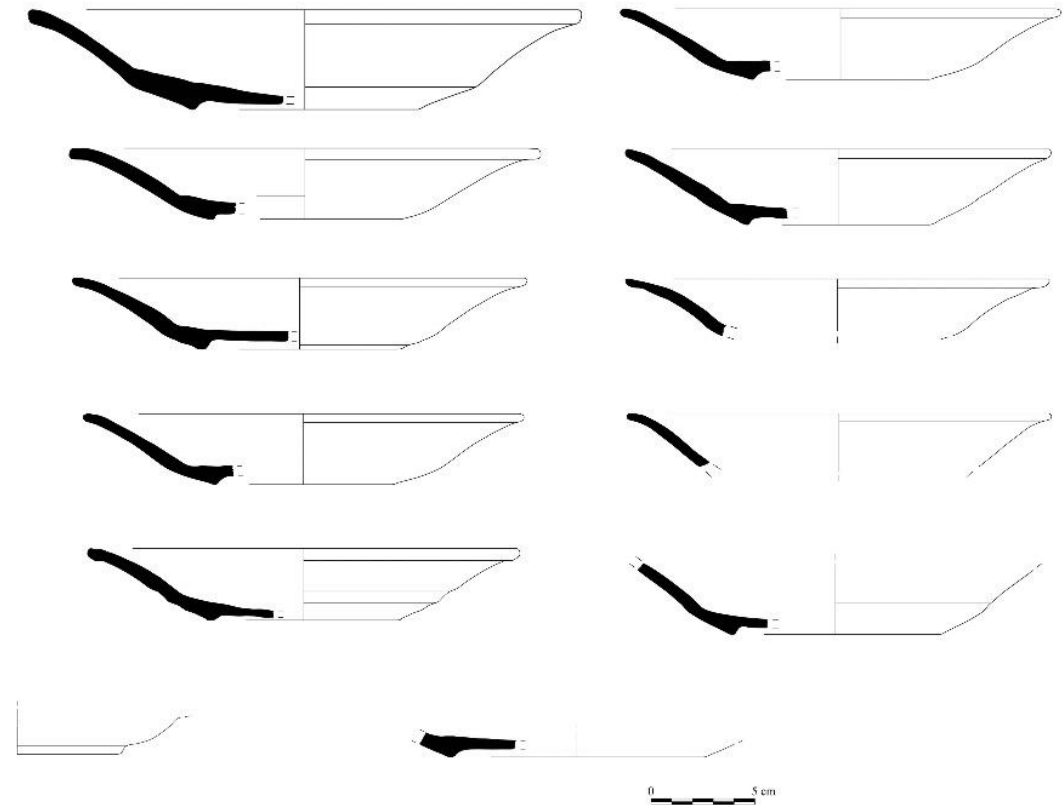

Acabado y decoración de *Talaverana Helechos- Plato IA aves*. En imagen, pieza procedente de la Catedral de Oviedo.

## *Talaverana Tricolor - Redoma I*

- Cronología pieza: 1600-1699
- Cronología contexto: XVII
- Centro de proveniencia: Talavera de la Reina

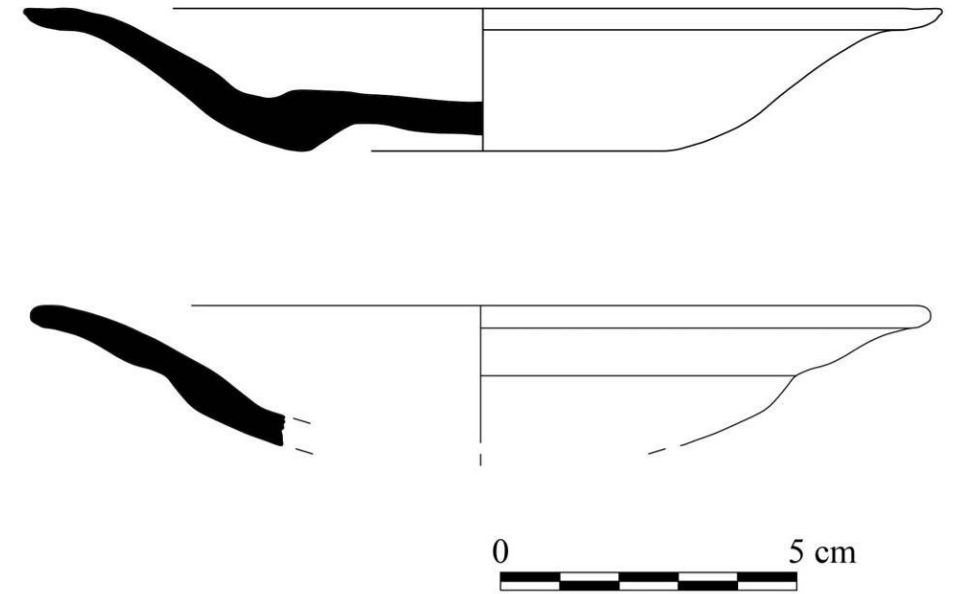
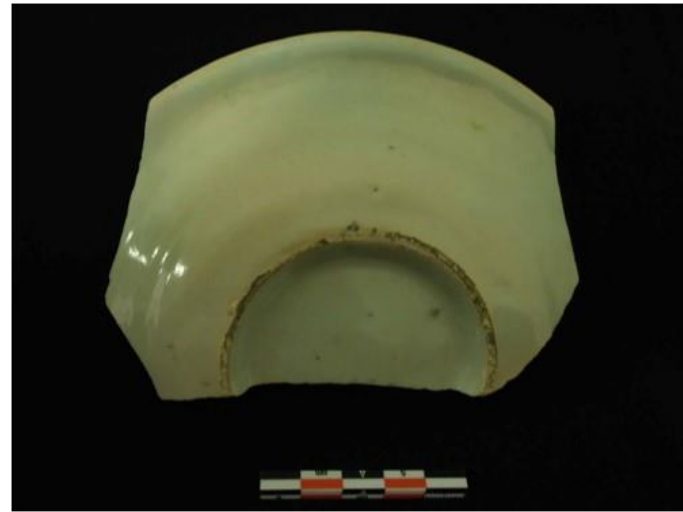

Acabado y decoración de *Polícroma Talaverana - Platito IA*. En imagen, piezas halladas en Oviedo.

## *Polícroma Talaverana - Cuenco II*

- Cronología pieza: 1600-1699
- Cronología contexto: XVII
- Centro de proveniencia: Talavera de la Reina

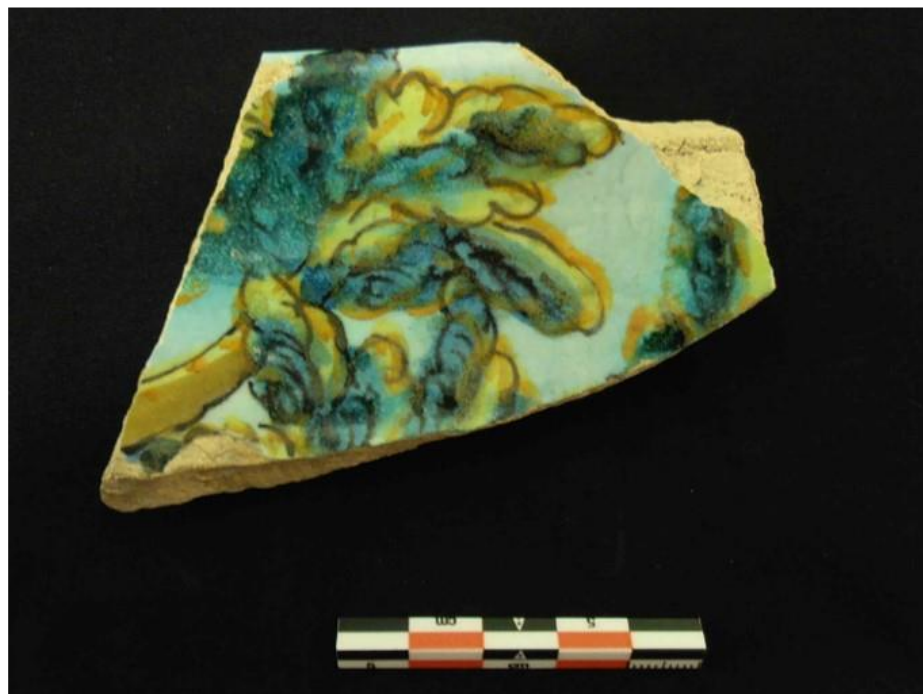
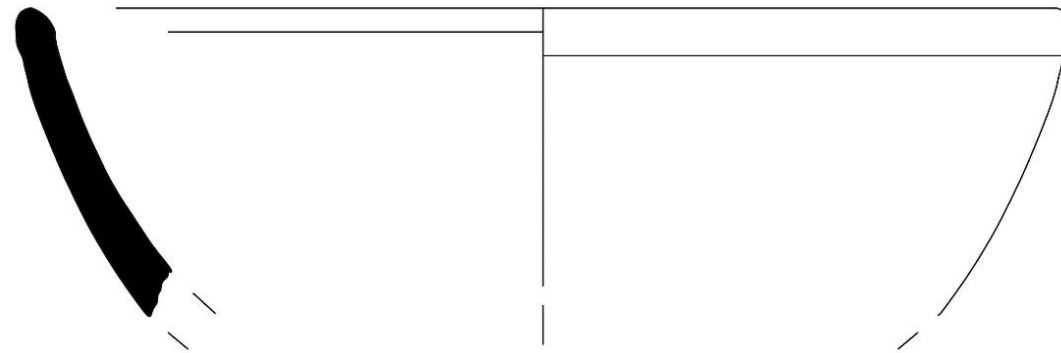

Acabado y decoración de *Polícroma Talaverana – Cuenco II*. En imagen, piezas halladas en Oviedo.





*Portuguesa Vila Nova - Plato IA*



*Portuguesa Vila Nova - Plato IB*

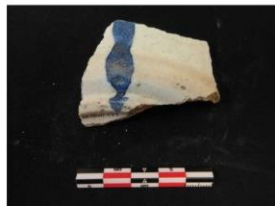
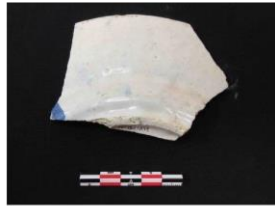

*Portuguesa Lisboa - Plato ID*

*Portuguesa Coímbra - Escudilla IA*



*Portuguesa Coímbra - Plato IA*



*Portuguesa Coímbra - Escudilla IC*



*Portuguesa Vermelha - Jarrita/o I*



*Portuguesa Lisboa - Plato ID*

- Cronología pieza: 1635-1660
- Cronología contexto: XVII
- Centro de proveniencia: Portugal - Lisboa

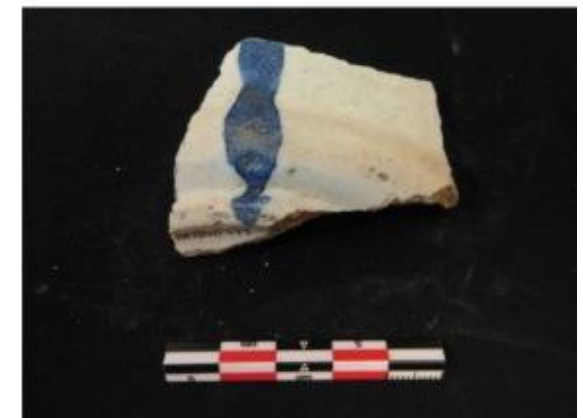
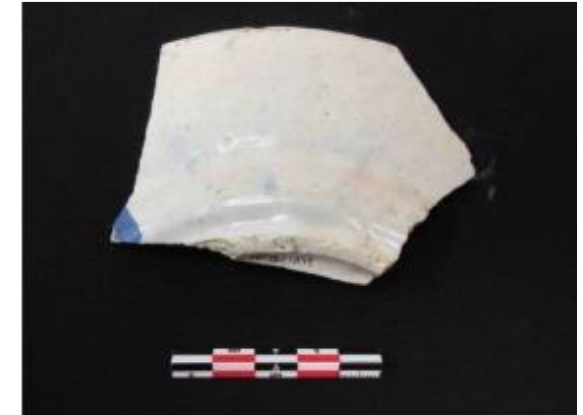
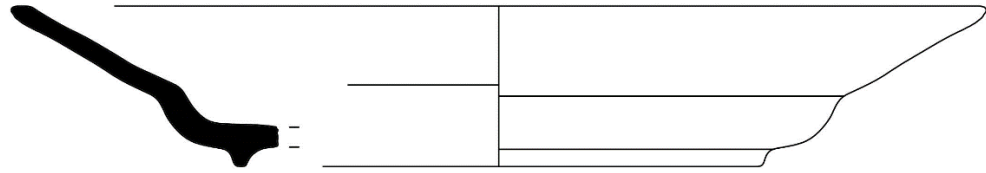

Acabado y decoración de *Portuguesa Lisboa - Plato ID*. En imagen, piezas halladas en Oviedo.







*Valenciana Dorada - Fuente I*



*Valenciana Dorada y azul - Escudilla I*

*Valenciana Azul - Escudilla I*

- Cronología pieza: 1500-1599
- Cronología contexto: XVI-XVII
- Centro de proveniencia: Valencia - Manises / Paterna



Acabado y decoración de *Valenciana Azul - Escudilla I*. En imagen, pieza procedente de Oviedo.

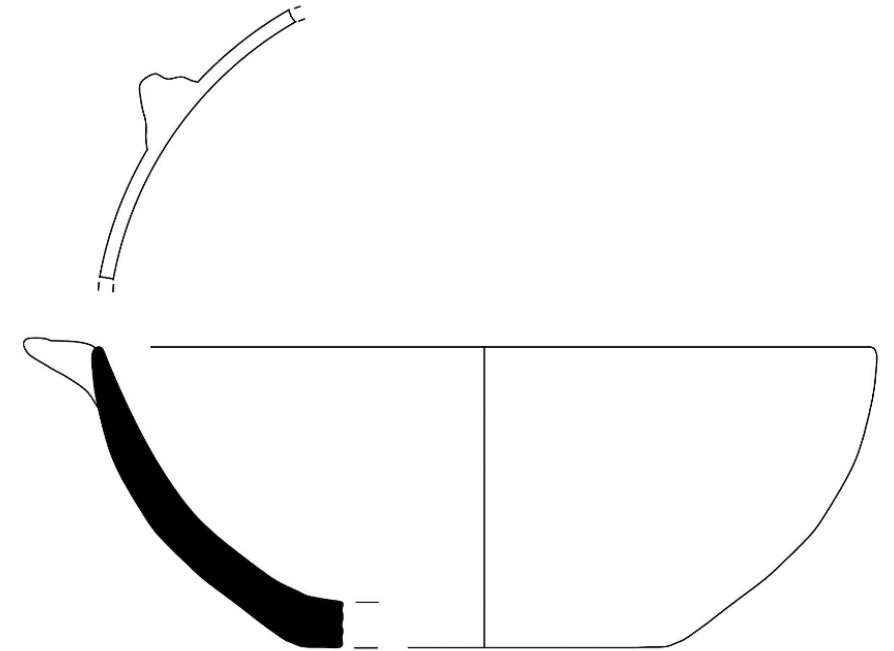

0 5 cm



*Valenciana Dorada y azul - Escudilla I*

- Cronología pieza: 1400-1499
- Cronología contexto: XV
- Centro de proveniencia: Valencia - Manises / Pater



Acabado y decoración de *Valenciana Dorada y azul - Escudilla I*. En imagen, pieza procedente de la calle Máximo y Fromestano (Oviedo).

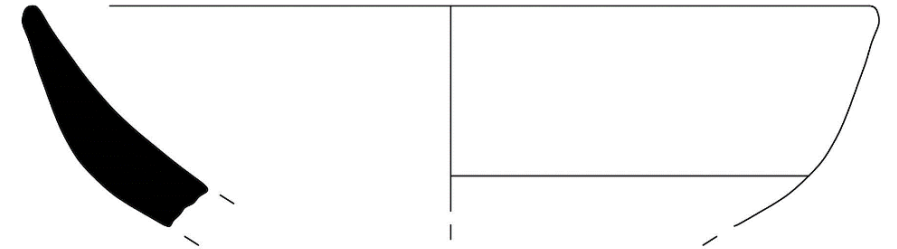

0 5 cm

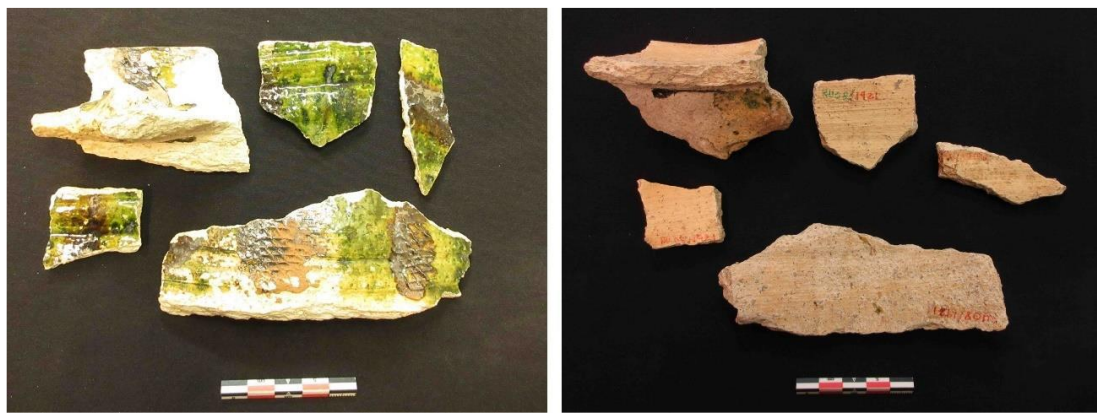

*Francesa del Centro-Suroeste (Saintonge) - Fuente I*



*Francesa del Centro-Suroeste (Saintonge) - Jarrita/o II*

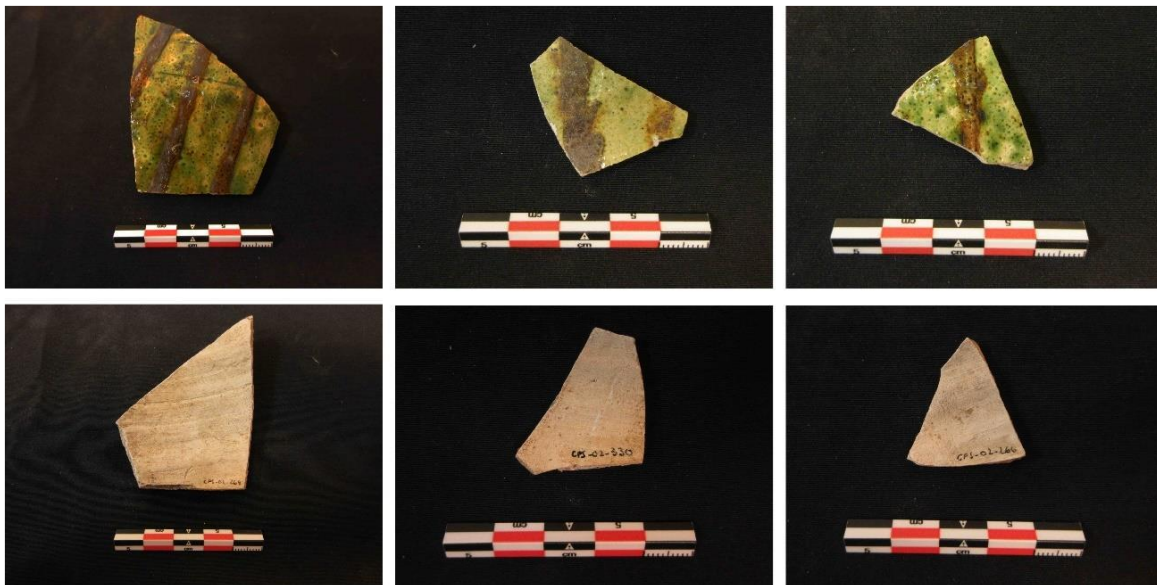

*Francesa del Centro-Suroeste (Saintonge) - Jarrita/o VII*



*Francesa del Noroeste (París-Ruan) - Fuente I*





*Holandesa Vidriada - Plato I*

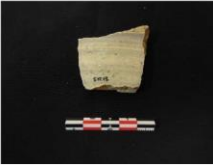

*Holandesa Maiolica - Fuente III*



*Holandesa Maiolica - Plato II*

*Holandesa Faience - Plato VI*



*Holandesa Faience - Plato IB*

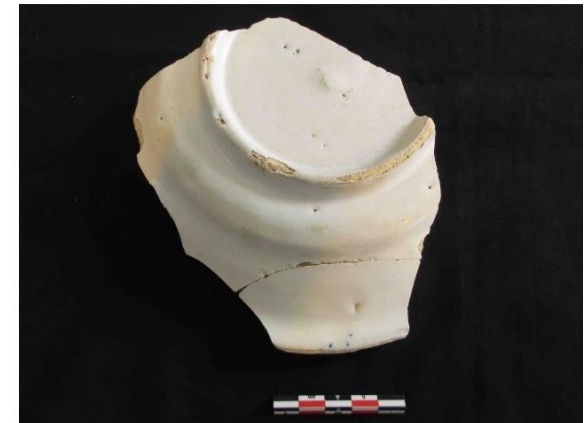

*Holandesa Faience - Plato IIC*

*Holandesa Faience - Plato V*

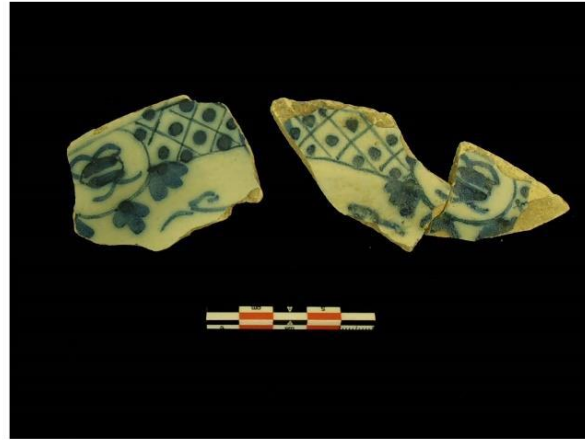

- Cronología pieza: 1675-1699
- Cronología contexto: XVII
- Centro de proveniencia: Holanda

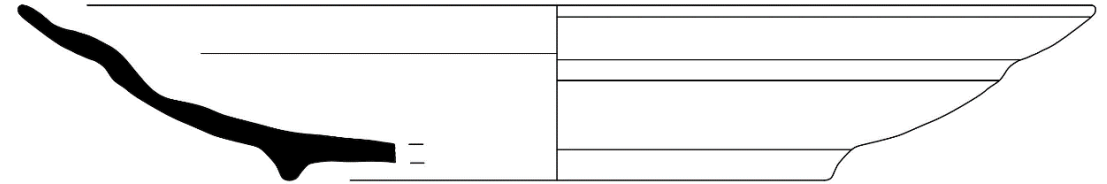

Acabado y decoración de *Holandesa Faience - Plato V*. En imagen, pieza hallada en la Catedral de Oviedo



## *Holandesa Maiolica - Jícara I*



Acabado y decoración de *Holandesa Maiolica - Jícara I*. En imagen, pieza hallada en la Catedral de Oviedo.

- Cronología pieza: 1575-1599
- Cronología contexto: XVI
- Centro de proveniencia: Holanda - Haarlem

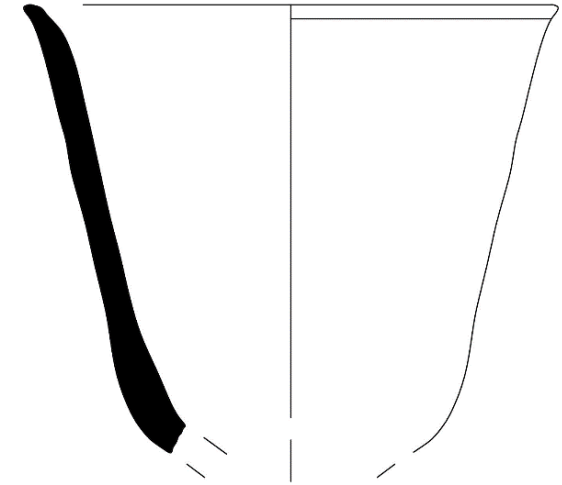

Cuenca de *maiolica*, Haarlem (Holanda), 1575-1600 (Gawronski et al., 2012, pp. 198, 320).

*Holandesa Faience - Jícara II*



Acabado y decoración de *Holandesa Faience - Jícara II*. En imagen, pieza hallada en la Catedral de Oviedo.

- Cronología pieza: 1675-1699
- Cronología contexto: XVII
- Centro de proveniencia: Holanda occidental

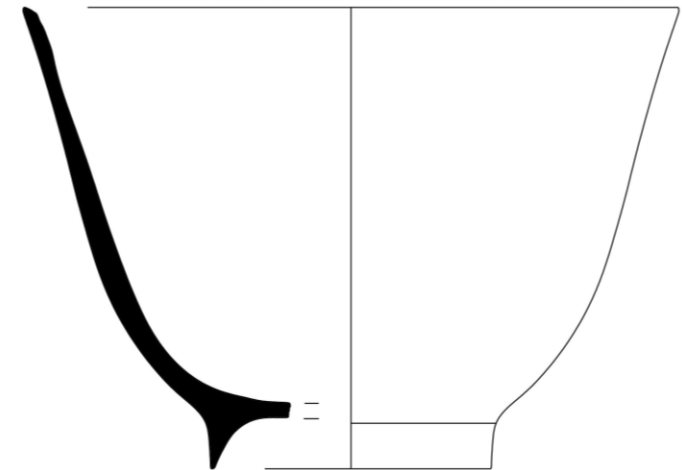



*Inglesa Vidriada - Fuente I*



*Inglesa Delftware - Plato I*

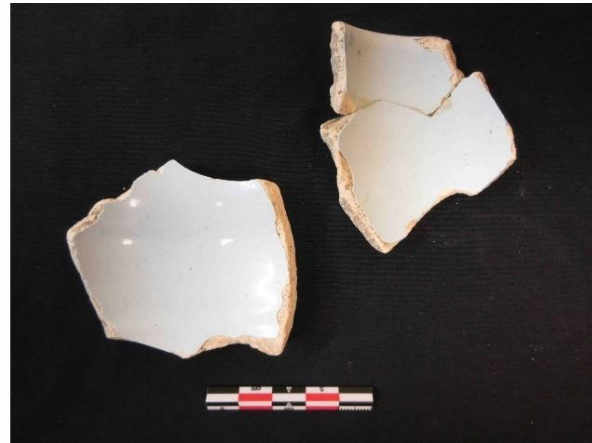

*Inglesa Delftware - Jarrita/o I*



*Inglesa Delftware - Fuente I*



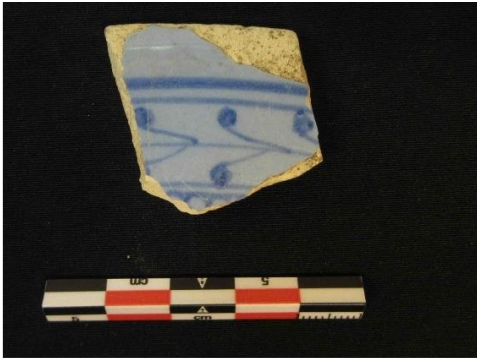

*Italiana Liguria - Plato I "berettino"*

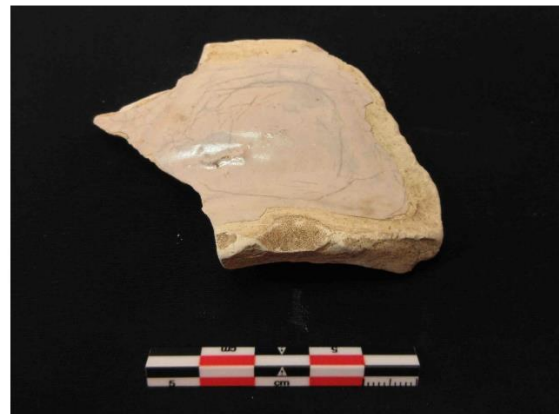

*Italiana Montelupo - Plato I "blu graffito"*



*Italiana Deruta - Cuenco I "a embricazioni"*



*Italiana Deruta - Plato I "a embricazioni"*



*Alemana Gres - Jarra IIIA Westerwald*

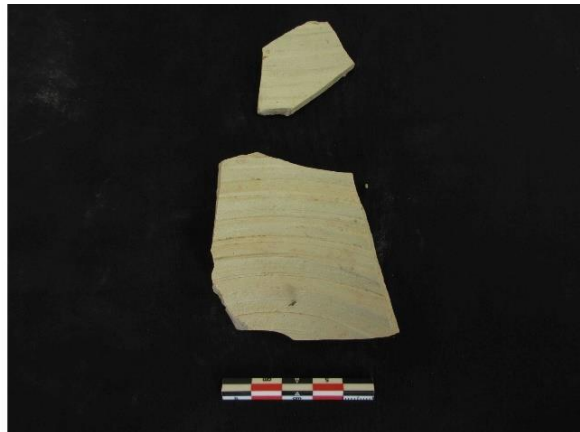

*Alemana Gres - Jarra IIIB Westerwald*



*Alemana Gres - Jarra IV Raeren*



*Alemana Gres - Jarra V Siegburg*





## *Alemana Gres - Jarra IIIB Westerwald*

- Cronología pieza: 1575-1625
- Cronología contexto: XVII
- Centro de proveniencia: Alemania - Westerwald



Acabado y decoración de *Alemana Gres - Jarra IIIB Westerwald*. En imagen, pieza procedente de la casa Carabajal Solís (Oviedo).

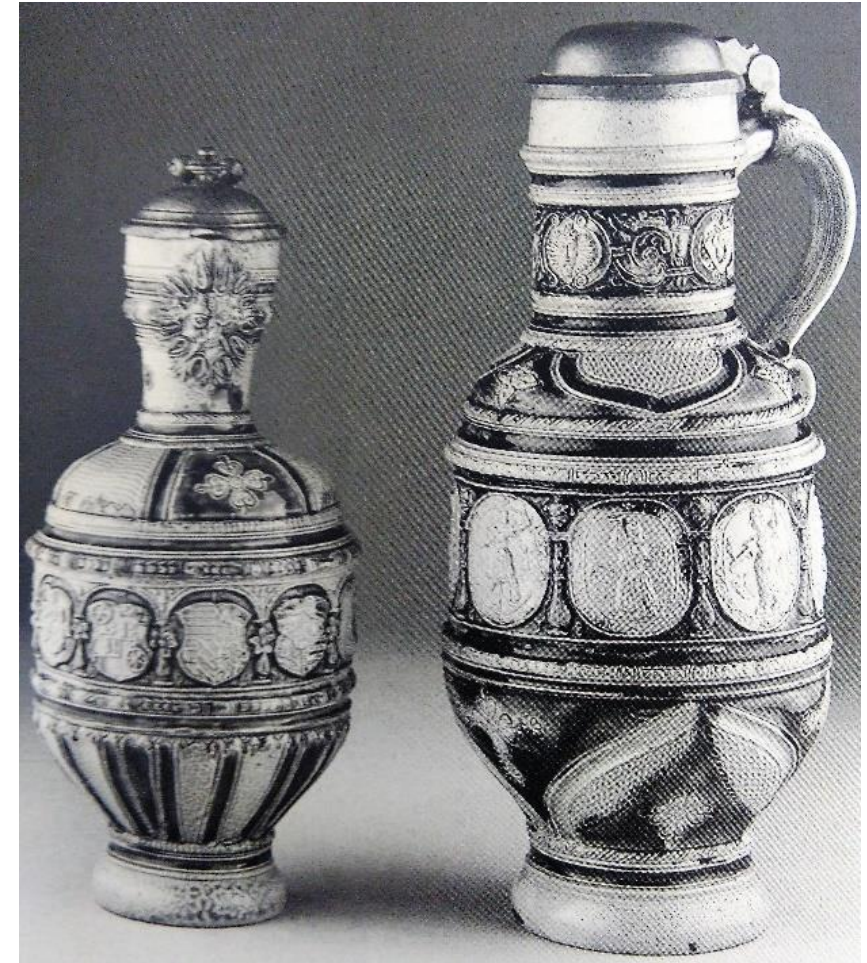

Dos jarras, Westerwald (Alemania), 1618 (Gaimster, 1997, p. 260).



## *Alemana Gres - Jarra IV Raeren*

- Cronología pieza: 1600-1625
- Cronología contexto: XVII
- Centro de proveniencia: Alemania - Raeren



Acabado y decoración de *Alemana Gres - Jarra IV Raeren*. En imagen, pieza procedente de la Calle de la Rúa nº14 (Oviedo).



Jarra de gres, Raeren, 1607. Inventario: 2836-1852, *Victoria and Albert Museum*, Londres.

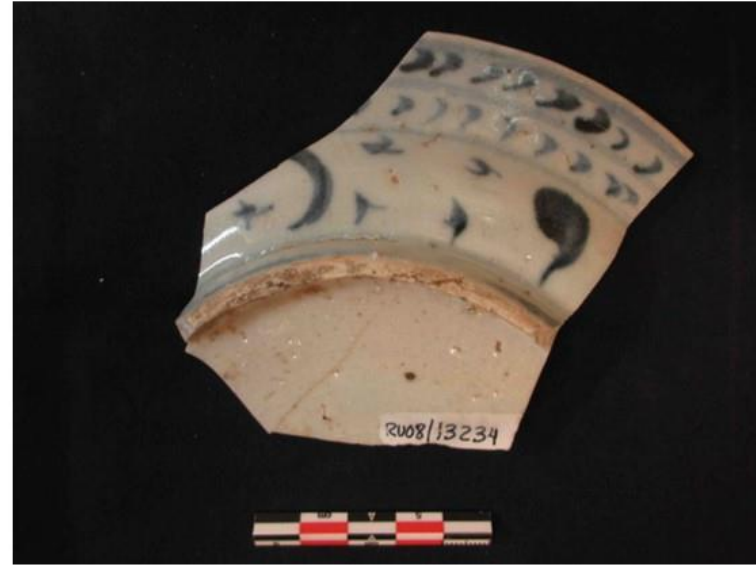
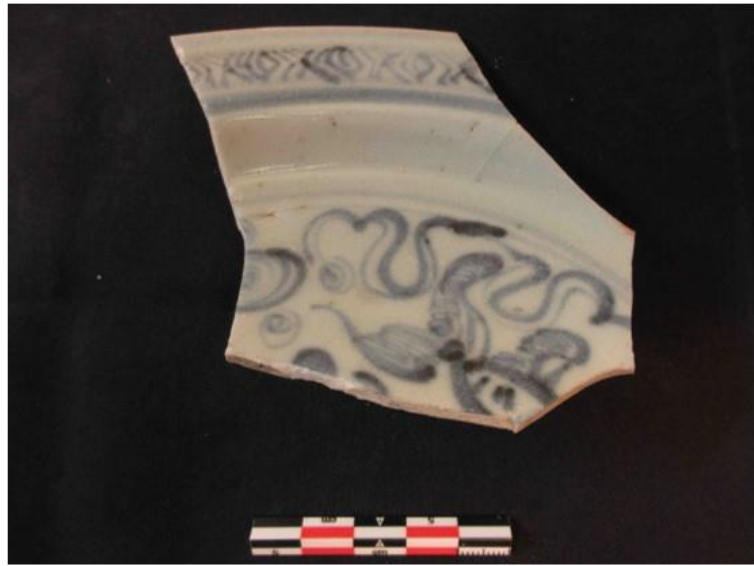

*China - Plato I*

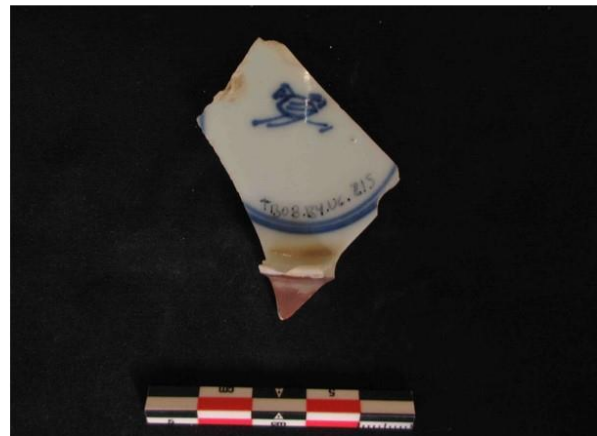
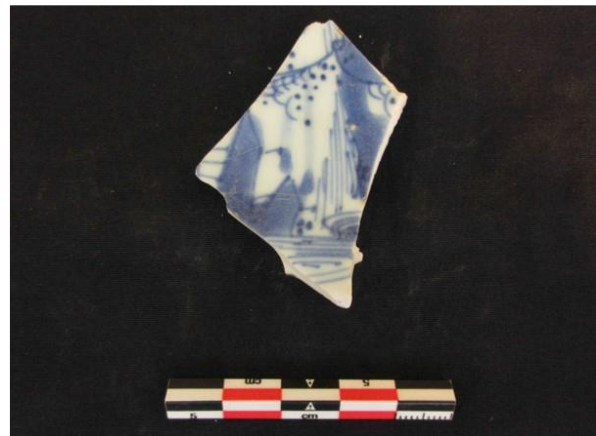

*China- Platito I*

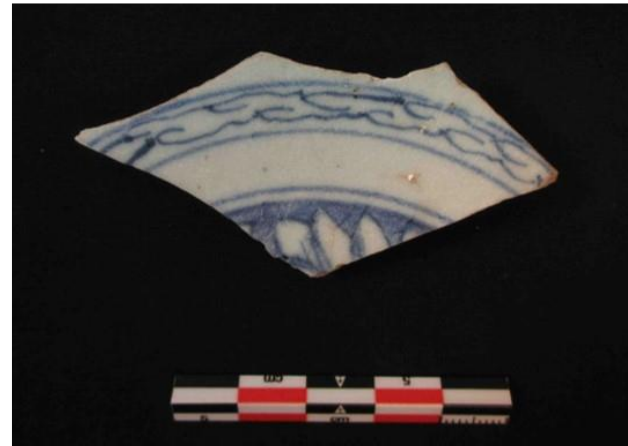

*China - Plato II*

# China - Plato II

- Cronología pieza: 1522-1566
- Cronología contexto: XVI
- Centro de proveniencia: China - Jingdezhen

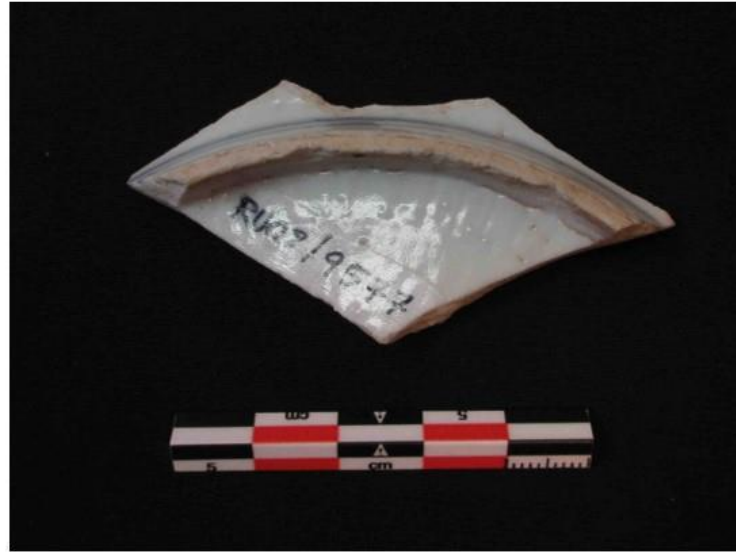
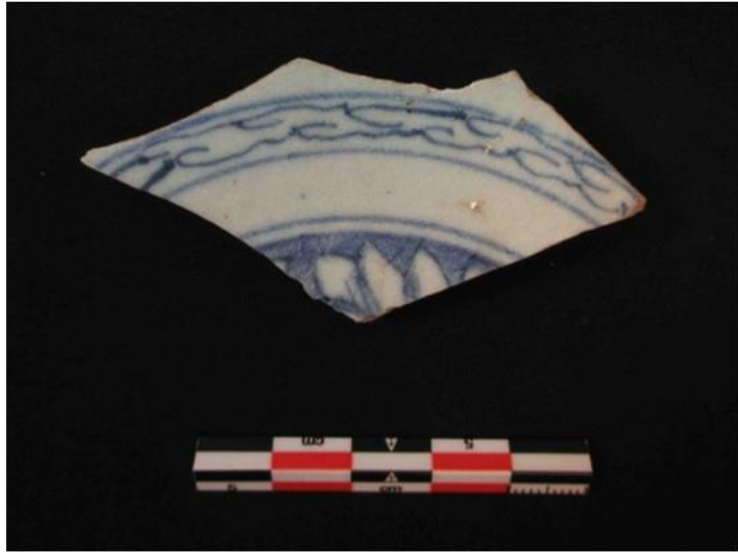

Anverso y reverso de *China - Plato II*, pieza hallada en la calle de la Rúa (Oviedo).

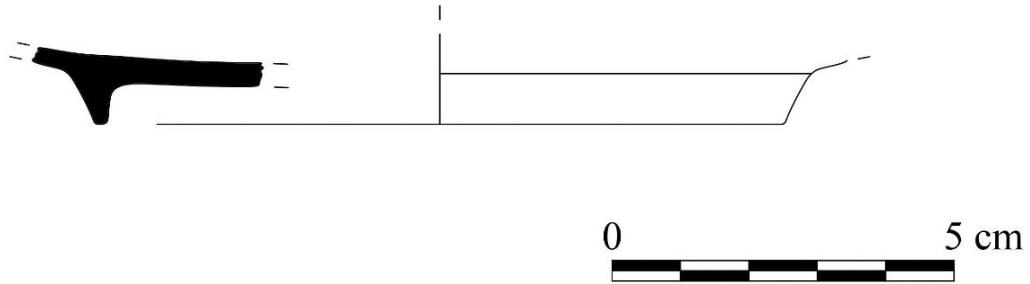

Plato porcelana, China – Jingdezhen (Krahe, 2014, p. 200-201, fig. 142).



*China - Plato I*

- Cronología pieza: 1506-1521
- Cronología contexto: XVI
- Centro de proveniencia: China - Shantou / Jingdezhen

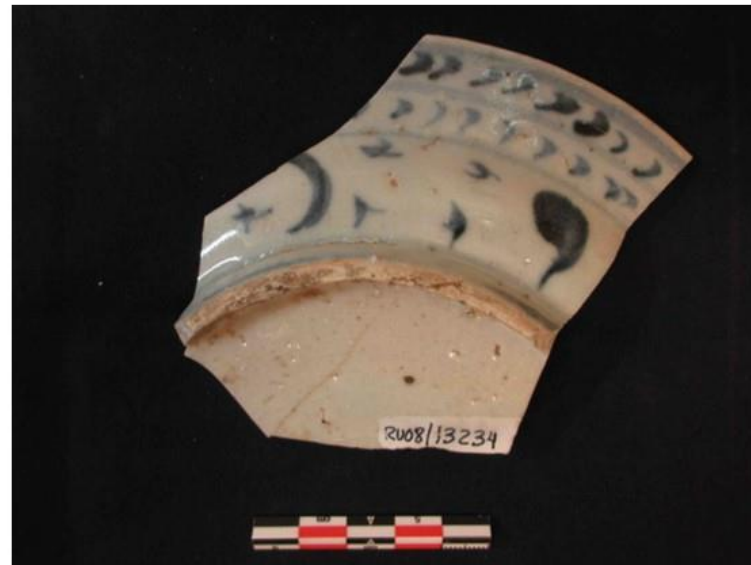
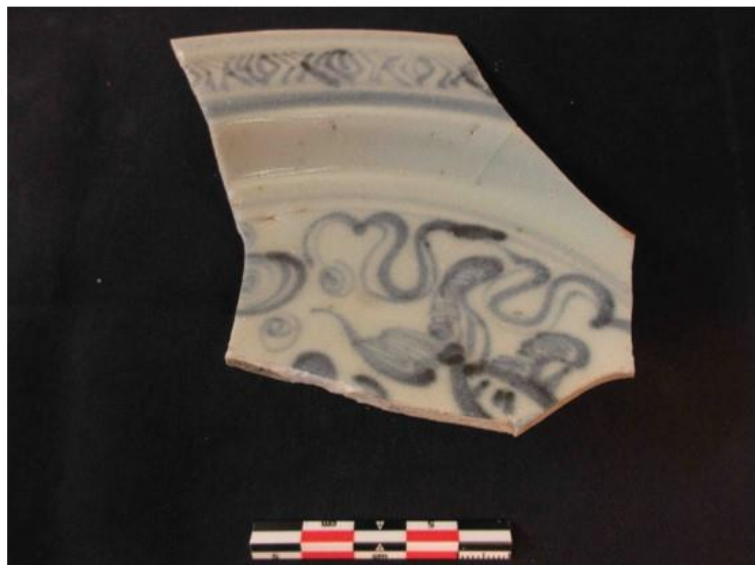

Anverso y reverso de *China - Plato I*. En imagen, pieza hallada en la calle de la Rúa (Oviedo).

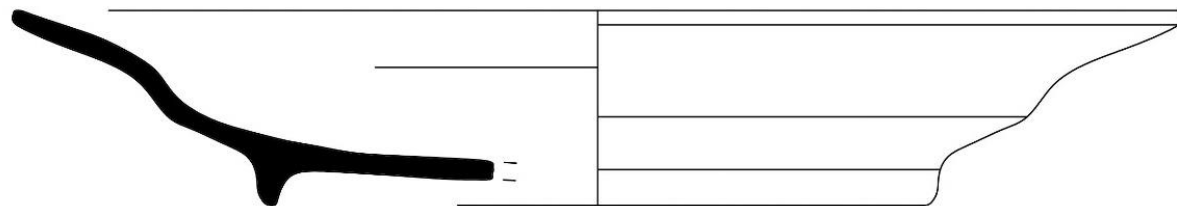

0 5 cm



Paralelo a *China - Plato I*. Rijksmuseum - N.º Inv. AK-MAK-1478.

# Cerámica post-medieval y pintura







ALH-POL-07-I-1028-5

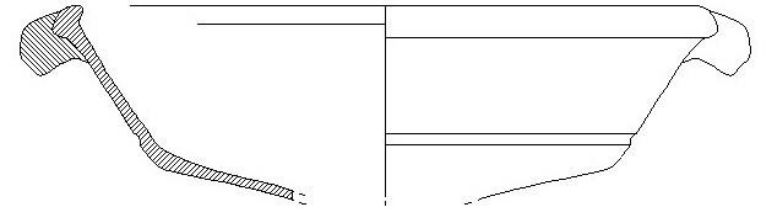

ALH-POL-07-I-1042-208

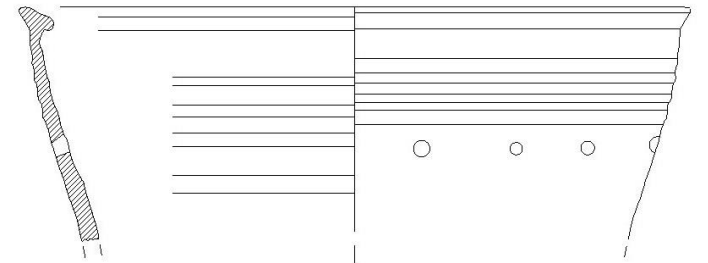





Francisco de Zurbarán (1598-1664), *San Hugo en el refectorio de los Cartujos*, c. 1630-1635. Óleo sobre lienzo, 262 x 307 cm. Museo de Bellas Artes, Sevilla.



Antonio Pereda (1611-1678), *Bodegón con dulces, vasijas y escritorio de ébano*. C. 1652. Óleo sobre lienzo, 80 x 94 cm. Museo del Hermitage, St. Petersburg.



*Holandesa Faience - Jícara II*



Acabado y decoración de *Holandesa Faience - Jícara II*. En imagen, pieza hallada en la Catedral de Oviedo.

- Cronología pieza: 1675-1699
- Cronología contexto: XVII
- Centro de proveniencia: Holanda occidental

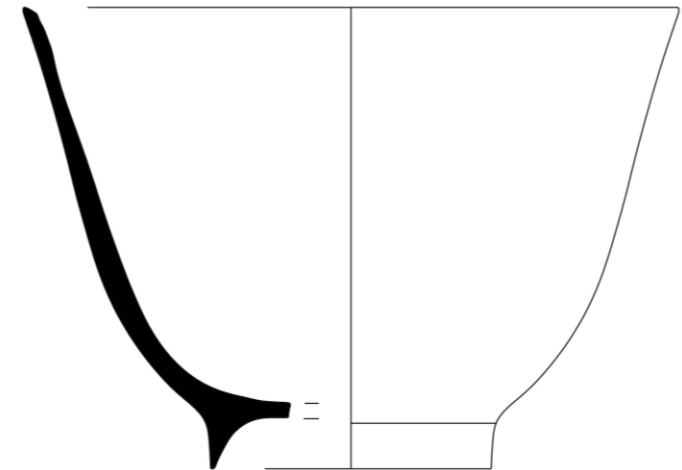





Antonio Pereda (1611-1678), *Bodegón con dulces, vasijas y escritorio de ébano*. C. 1652. Óleo sobre lienzo, 80 x 94 cm. Museo del Hermitage, St. Petersburg.

## *Talaverana Tricolor - Redoma I*

- Cronología pieza: 1652
- Cronología contexto: XVII
- Centro de proveniencia: Talavera de la Reina

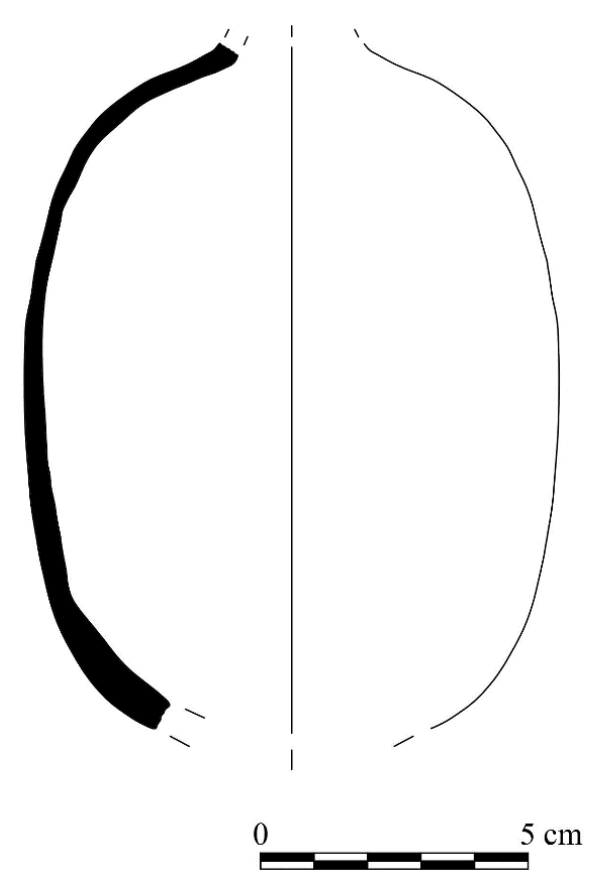

Decoración y acabado de *Talaverana Tricolor - Redoma I*. En imagen, pieza hallada en la Catedral de Oviedo.





Hugo Van der Goes (1440-1482), *Adoración de los Pastores en el Triptico Portinari*, c. 1476-1478. Óleo sobre tabla, 253 x 304 cm. Galería Uffizi, Florencia.



*Valenciana Dorada y azul - Escudilla I*

- Cronología pieza: 1400-1499
- Cronología contexto: XV
- Centro de proveniencia: Valencia - Manises / Pater



Acabado y decoración de *Valenciana Dorada y azul - Escudilla I*. En imagen, pieza procedente de la calle Máximo y Fromestano (Oviedo).

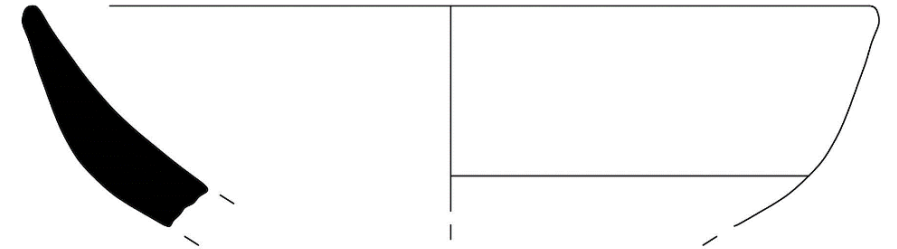

0 5 cm



Luis Egidio Meléndez (1716-1780), *Bodegón con limas, caja de jalea, mariposa y recipientes*, tercer cuarto del siglo XVIII. Óleo sobre lienzo, 35 x 48 cm. Museo del Prado, Madrid.

*Mexicana - Miniatura Tibor I*

- Cronología pieza: 1651-1699
- Cronología contexto: XVII
- Centro de proveniencia: México - Tonalá

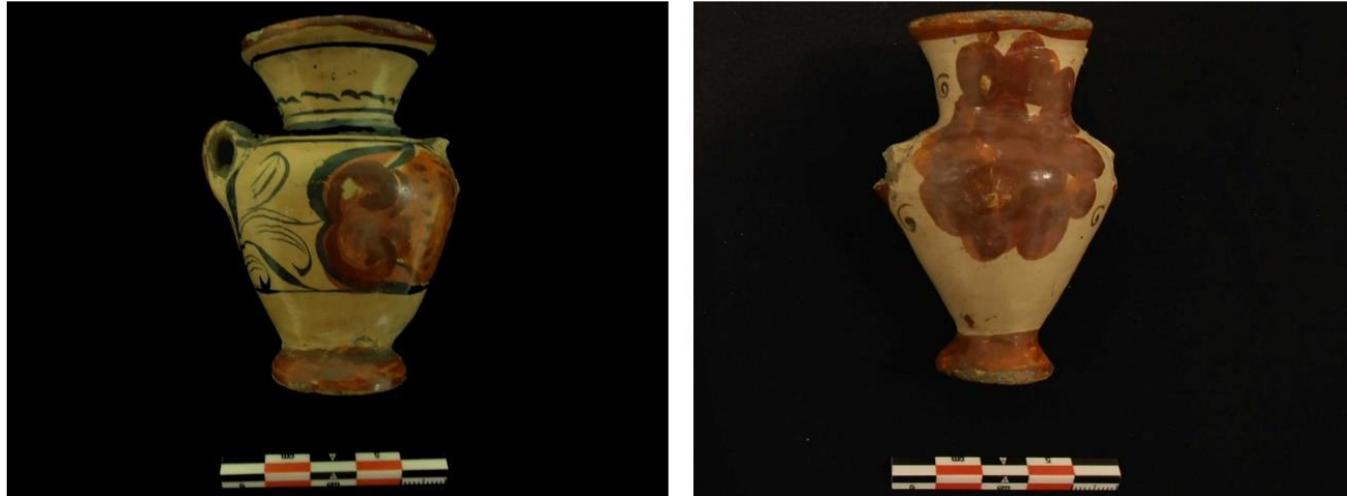

Acabado y decoración de *Mexicana - Miniatura Tibor I*. En imagen, piezas halladas en la Catedral de Oviedo.

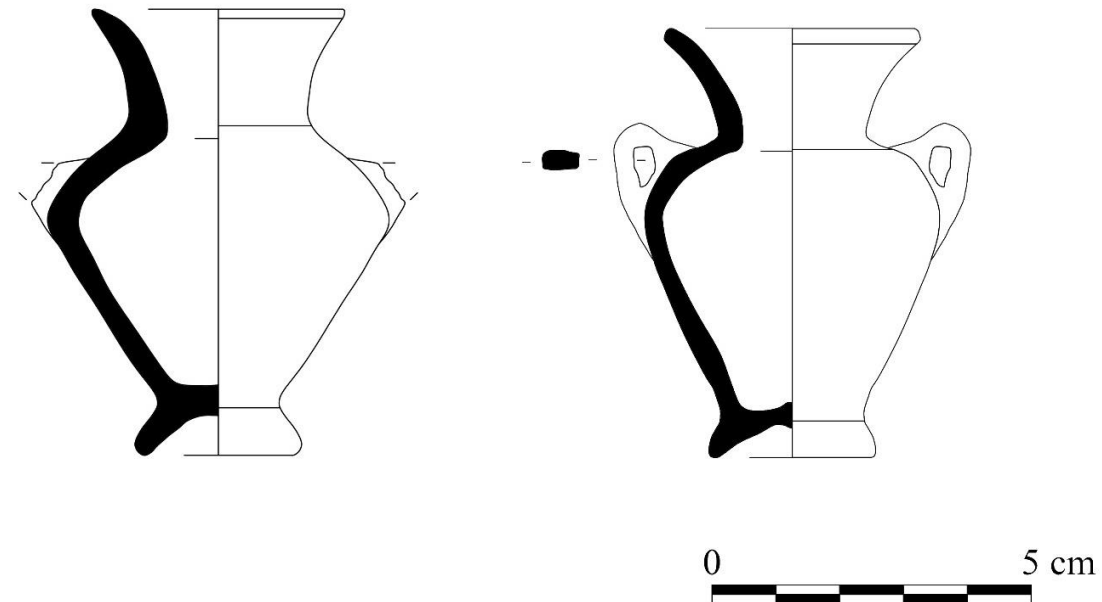









Anónimo, *El bodegonero*, c. 1610-1625. Óleo sobre lienzo, 100 x 122 cm. Rijksmuseum, Ámsterdam.

*Aragonesa Talaverana - Cuenco I tricolor*

- Cronología pieza: 1600-1699
- Cronología contexto: XVII
- Centro de proveniencia: Aragón - Villafeliche

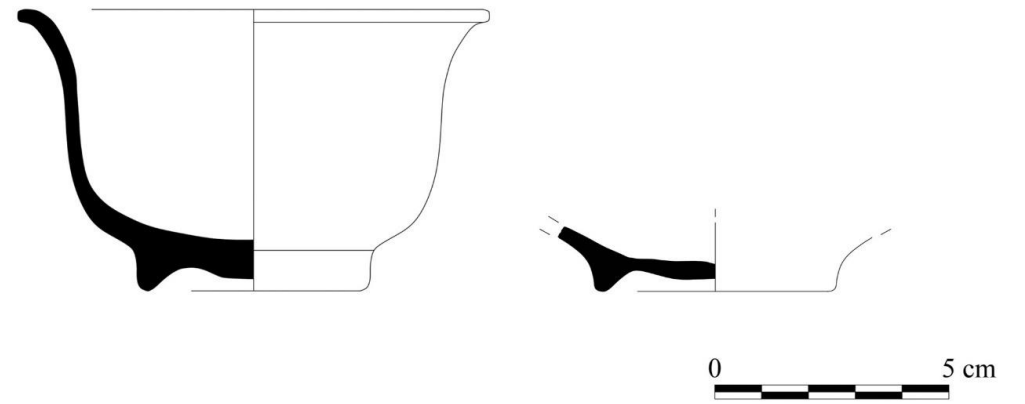

Acabado y decoración de *Aragonesa Talaverana - Cuenco I tricolor*.  
En imagen piezas procedentes de la Catedral.





Fray Juan Andrés Rizi (1600-1681), *La cena de San Benito*.  
Siglo XVII. Óleo sobre lienzo, 185x216 cm. Museo del  
Prado, Madrid.

## *Talaverana Tricolor - Tintero I*

- Cronología pieza: 1600-1650
- Cronología contexto: XVII
- Centro de proveniencia: Talavera de la Reina

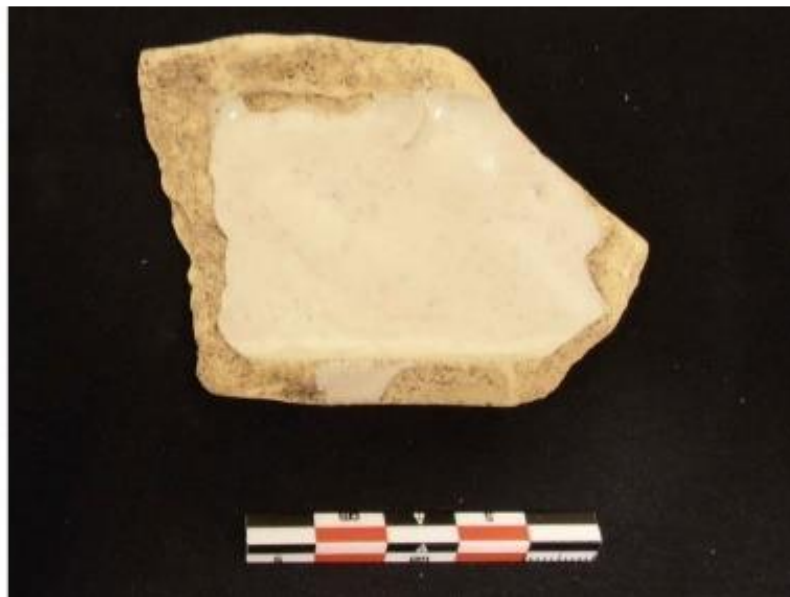
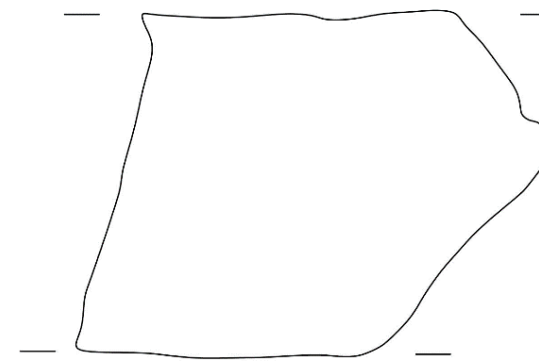
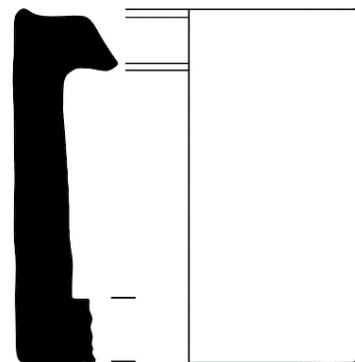

Decoración y acabado de *Talaverana Tricolor - Tintero I*. En imagen, pieza hallada en la Catedral de Oviedo.



Anónimo, *Naturaleza muerta con uvas, peras, vidrio y búcaro*, c. 1625. Óleo sobre lienzo, 70 x 83 cm. Colección Santander Central Hispano.



Michiel Jansz. van Mierevelt (1566-1641), *Civic guard banquet*, c. 1611.  
Óleo sobre lienzo. Museum Prinsenhof, Delft (Holanda).



## *Alemana Gres - Jarra IV Raeren*

- Cronología pieza: 1600-1625
- Cronología contexto: XVII
- Centro de proveniencia: Alemania - Raeren

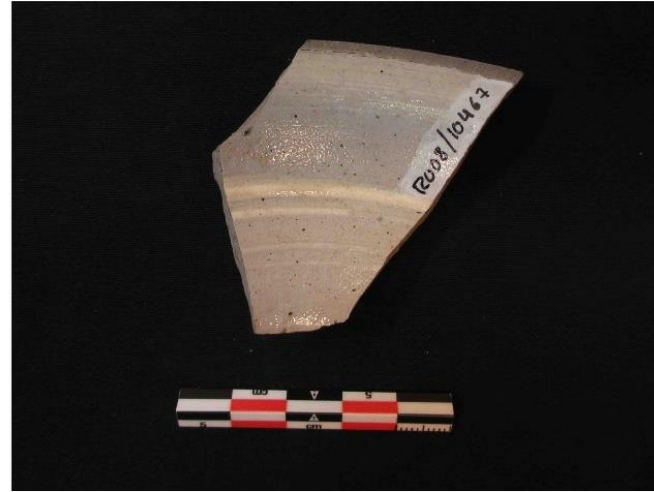

Acabado y decoración de *Alemana Gres - Jarra IV Raeren*. En imagen, pieza procedente de la Calle de la Rúa nº14 (Oviedo).



Jarra de gres, Raeren, 1607. Inventario: 2836-1852, *Victoria and Albert Museum*, Londres.





Diego Rodríguez de Silva y Velázquez (1599-1660), *Santa Rufina*, c. 1629-1632. Óleo sobre lienzo, 79 x 64 cm.  
Hospital de los Venerables, Sevilla





Bartolomé Esteban Murillo (1618-1682), *La cocina de los ángeles*, c. 1646. Óleo sobre lienzo, 180 x 450 cm. Museo del Louvre, París.



Juego de cuenco y plato formado por las tipologías *Talaverana Blanca - Cuenco I* y *Talaverana Blanca - Plato I*. En imagen, piezas procedentes de la calle de la Rúa n.º 16 (Oviedo).





Josefa de Óbidos (1630-1684), *Natureza-morta com caixas, vidro e pote de barro*, c. 1660-1670. Óleo sobre lienzo. Museu Nacional de Arte Antiga, Lisboa.





Acabado y decoración de *Portuguesa Vila Nova - Cuenco I*  
(Fernández Ochoa & González Lafita, 1989, p. 103).



David Teniers (1610–1690), *Fumadores y bebedores*, c. 1652. Óleo sobre tabla, 34 x 48 cm. Museo del Prado, Madrid.



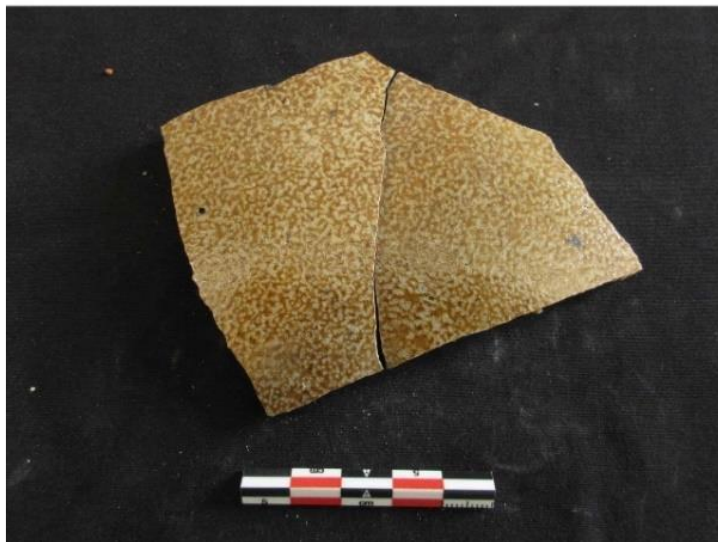
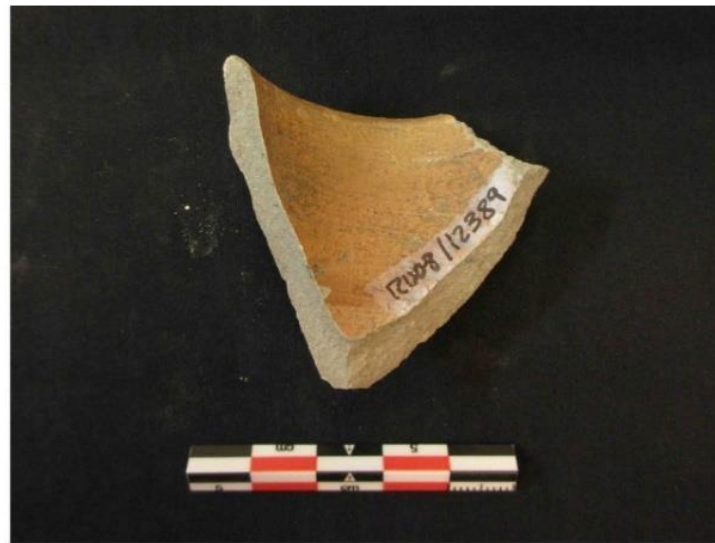

Acabado de *Alemana Gres - Jarra / Frechen*. En imagen, piezas halladas en Gijón.





Piezas de *Holandesa Pipa Caolín* procedentes del pecio Ribadeo A (Blanco Patiño, 2011, p. 20).





Luis Egidio Meléndez (1716-1780). En la parte izquierda: *Bodegón dos perdices, cebollas, ajos y vasijas*, último cuarto del siglo XVIII. Óleo sobre lienzo, 41,6 x 62,3 cm. A la derecha: *Bodegón con arenques, cebolletas, pan y utensilios de cocina*, c. 1760 - 1770. Óleo sobre lienzo, 50,3 x 36,7 cm. Museo del Prado, Madrid.



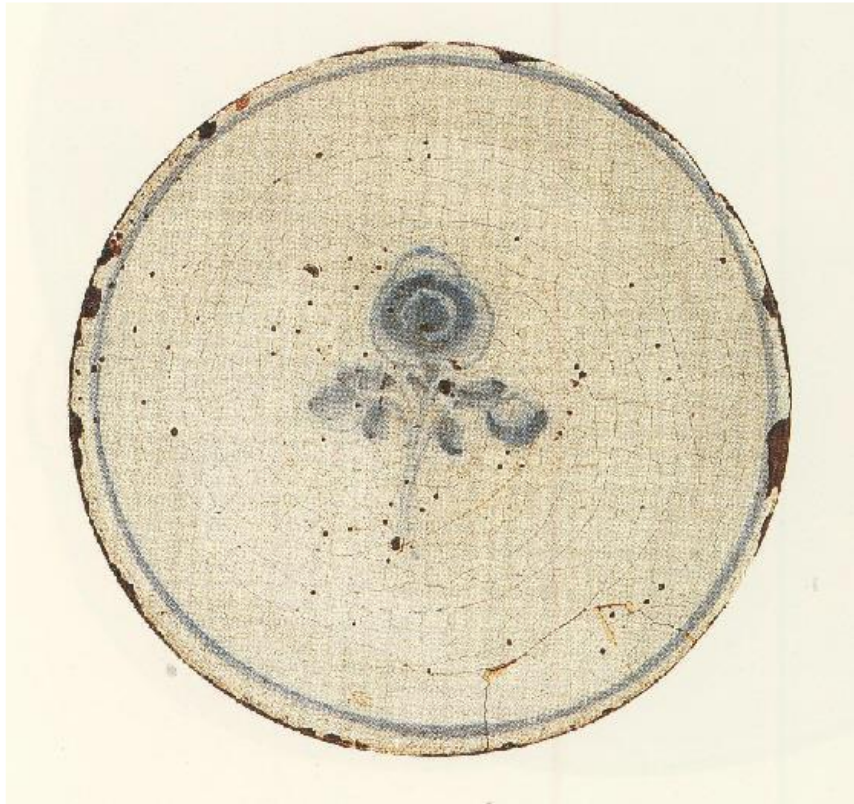

Talavera serie adormidera. Museo de Santa Cruz (Inventario DO2001/28/149), una producción del siglo XIX elaborada en Talavera de la Reina.



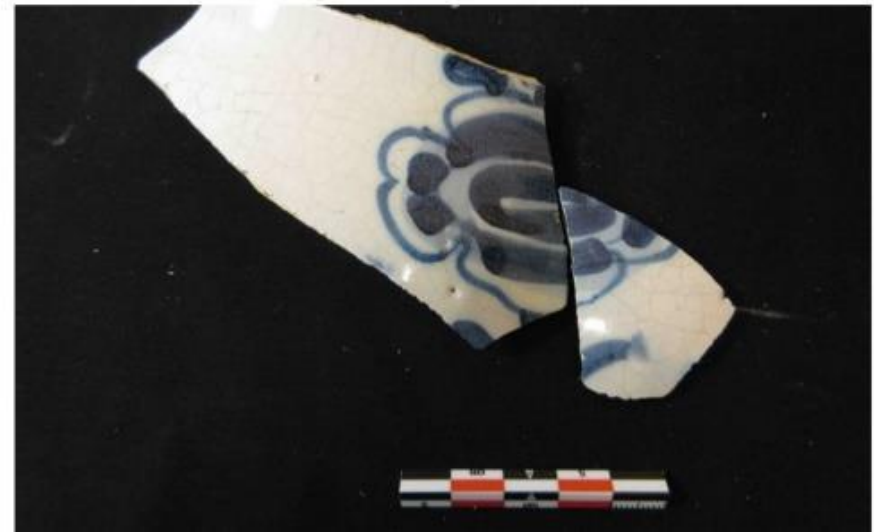

Luis Egidio Meléndez (1716-1780), *Bodegón con plato de cerezas, ciruelas, jarra y queso*, c. 1760. Óleo sobre lienzo, 47 x 35 cm. Museo del Prado, Madrid.

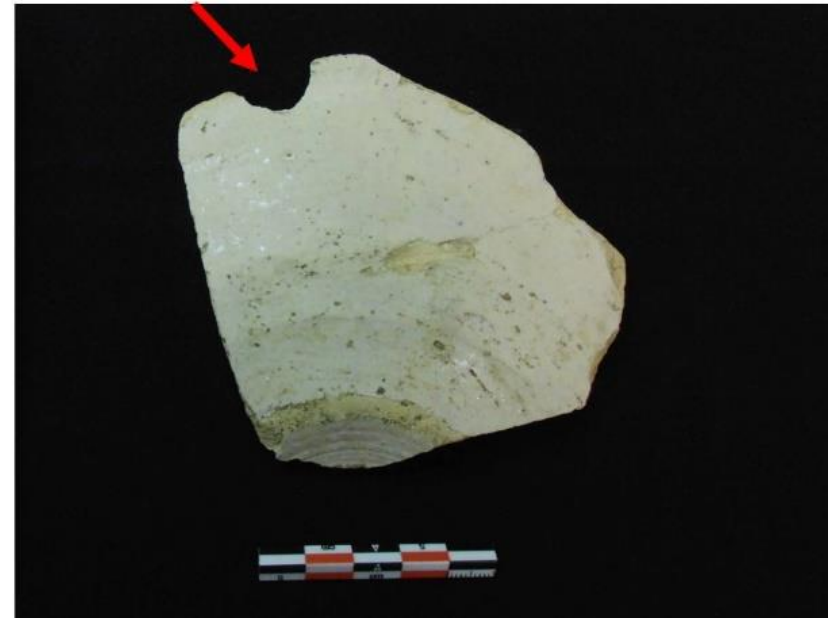

Luis Egidio Meléndez (1716-1780), *Bodegón con arenques, cebolletas, pan y utensilios de cocina*, c. 1760-1770. Óleo sobre lienzo, 50,3 x 36,7 cm. Museo del Prado, Madrid (izquierda). Pared de plato recortada para utilizar como ficha (parte superior derecha). Plato reutilizado como tapadera y con una muesca para poder introducir la cuchara sin necesidad de destapar el recipiente (parte inferior derecha).





Antonio Pereda (1611-1678),  
*Escena de cocina o Alegoría de  
la virtud perdida*, c. 1650-  
1665.







## Alemana Gres - Jarra IIIB Westerwald



Acabado y decoración de *Alemana Gres - Jarra IIIB Westerwald*. En imagen, pieza procedente de la casa Carabajal Solís (Oviedo).



- Cronología pieza: 1575-1625
- Cronología contexto: XVII
- Centro de proveniencia: Alemania - Westerwald



Dos jarras, Westerwald (Alemania), 1618 (Gaimster, 1997, p. 260).







*Holandesa Faience - Plato V*

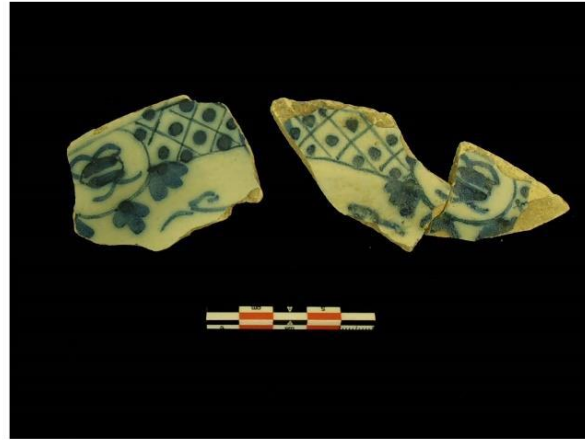

- Cronología pieza: 1675-1699
- Cronología contexto: XVII
- Centro de proveniencia: Holanda

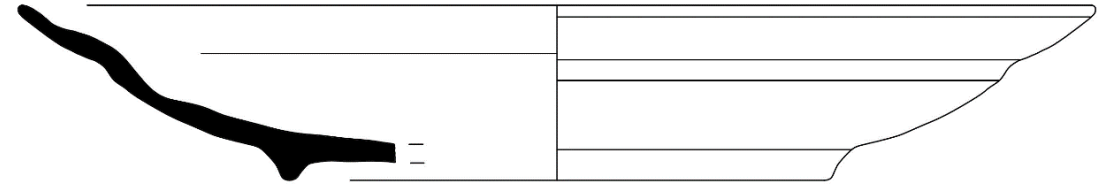

Acabado y decoración de *Holandesa Faience - Plato V*. En imagen, pieza hallada en la Catedral de Oviedo







*Sevillana Verde lisa - Lebrillo II*

- Cronología pieza: 1500-1599
- Cronología contexto: XVI
- Centro de proveniencia: Sevilla



Acabado y decoración de *Sevillana Verde lisa - Lebrillo II*. En imagen, pieza hallada en el palacio de Valdecarzana (Avilés).

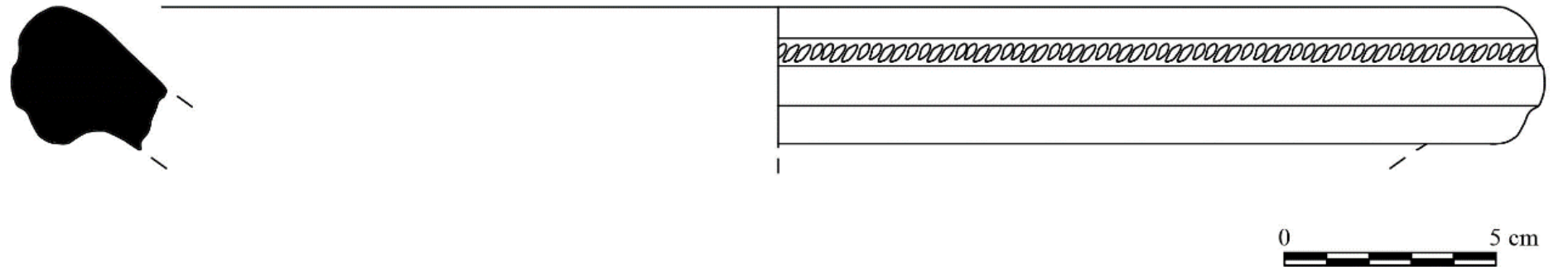





*Talaverana Helechos - Plato IA aves*



Acabado y decoración de *Talaverana Helechos- Plato IA aves*. En imagen, pieza procedente de la Catedral de Oviedo.

- Cronología pieza: 1620-1725
- Cronología contexto: XVII-XVIII
- Centro de proveniencia: Talavera de la Reina

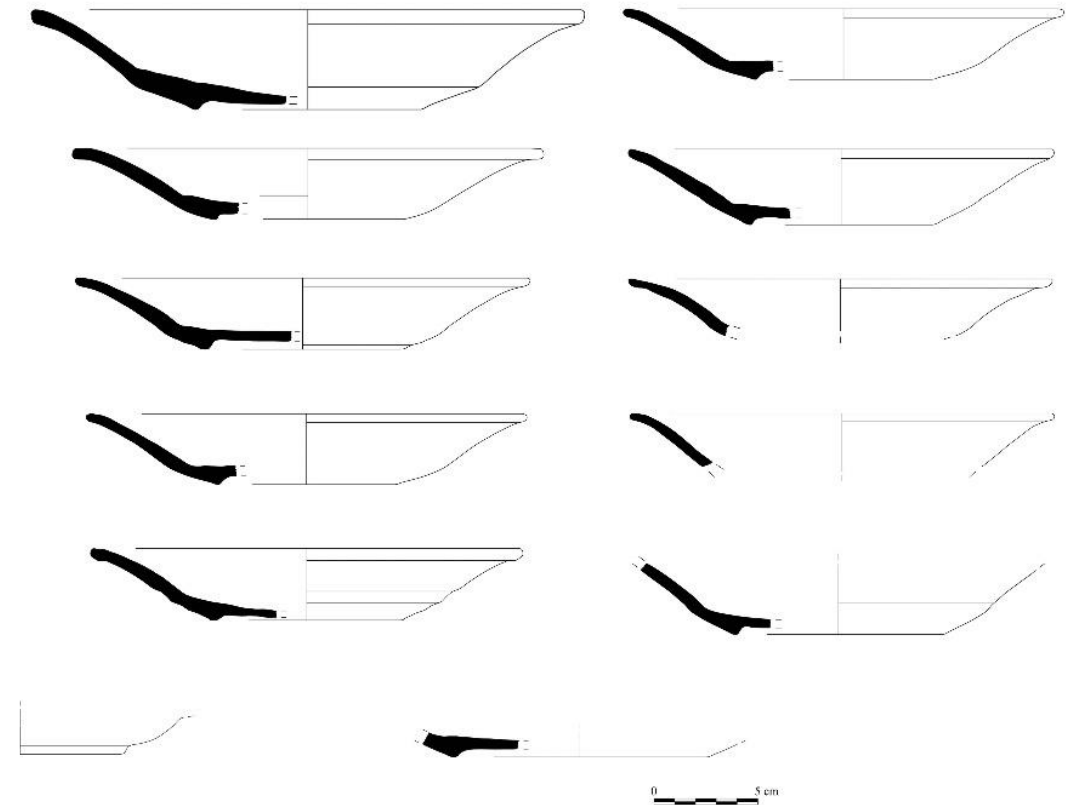









*Mexicana - Miniatura Tibor I*

- Cronología pieza: 1651-1699
- Cronología contexto: XVII
- Centro de proveniencia: México - Tonalá

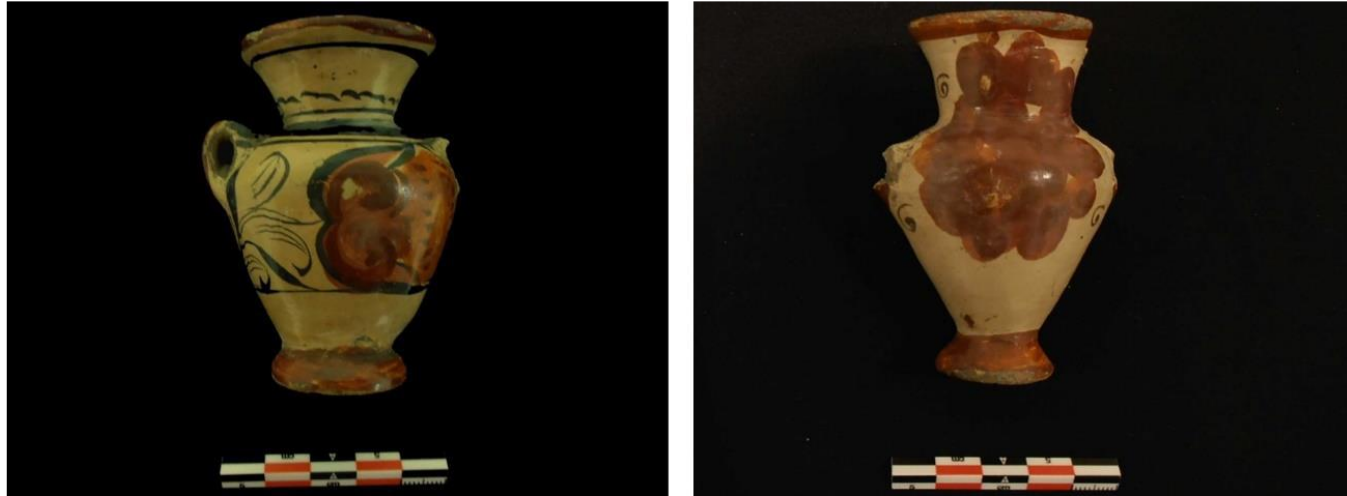

Acabado y decoración de *Mexicana - Miniatura Tibor I*. En imagen, piezas halladas en la Catedral de Oviedo.

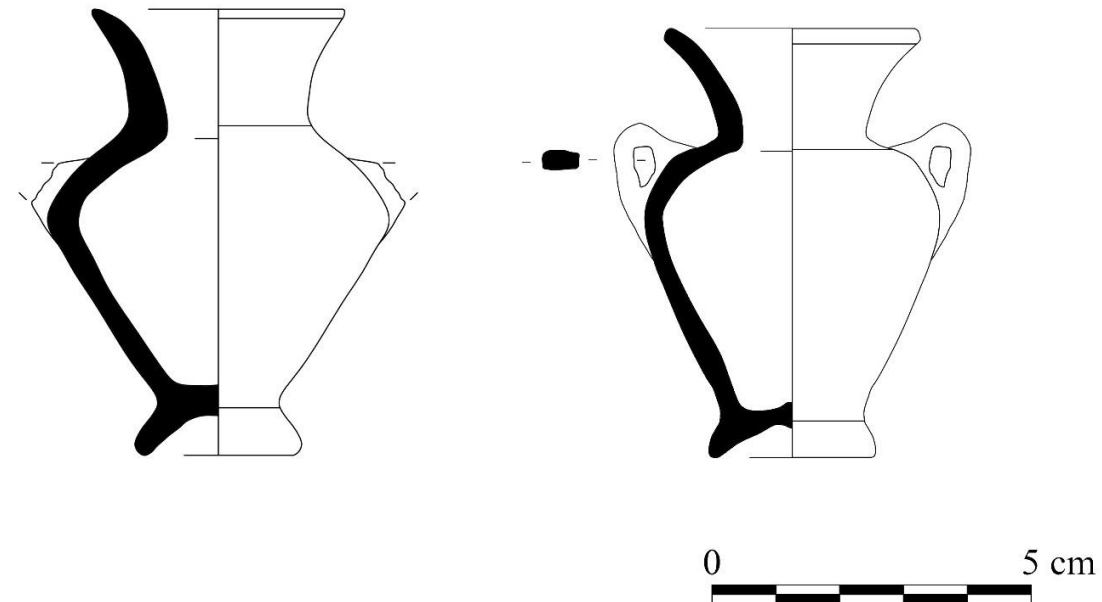







*Portuguesa Lisboa - Plato ID*

- Cronología pieza: 1635-1660
- Cronología contexto: XVII
- Centro de proveniencia: Portugal - Lisboa

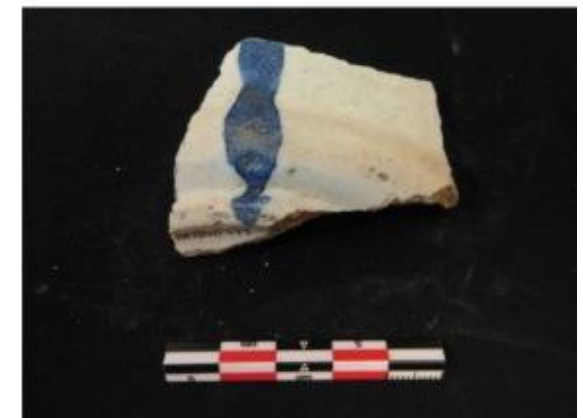
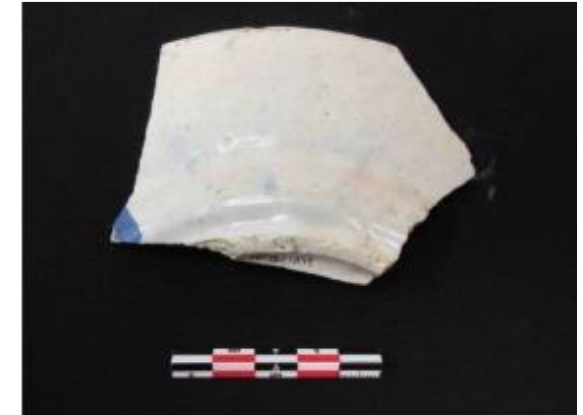
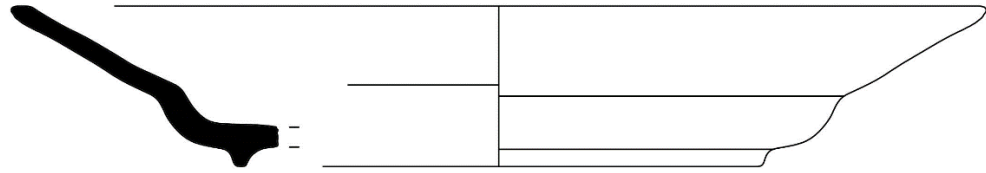

Acabado y decoración de *Portuguesa Lisboa - Plato ID*. En imagen, piezas halladas en Oviedo.







*Aragonesa Talaverana - Cuenco I tricolor*

- Cronología pieza: 1600-1699
- Cronología contexto: XVII
- Centro de proveniencia: Aragón - Villafeliche

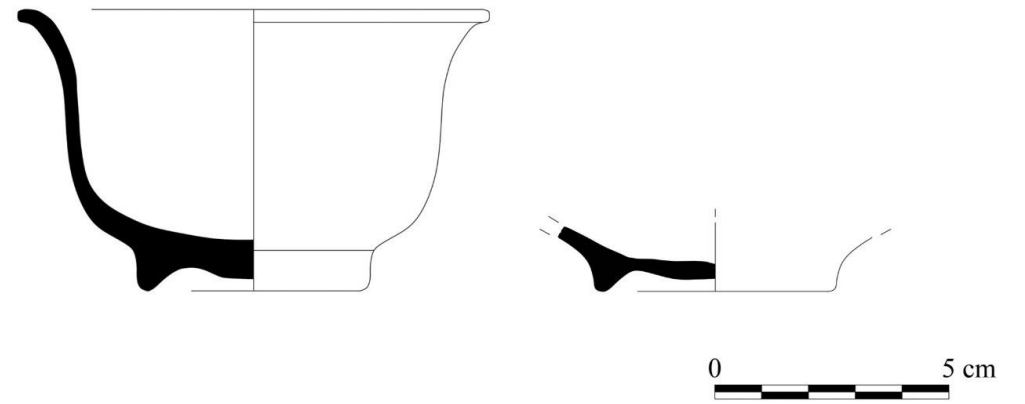

Acabado y decoración de *Aragonesa Talaverana - Cuenco I tricolor*.  
En imagen piezas procedentes de la Catedral.



## *Vasca Azul - Escudilla IA*

- Cronología pieza: 1650-1699
- Cronología contexto: XVII
- Centro de proveniencia: País Vasco - Erentxun - Egileta



Acabado y decoración de *Vasca Azul - Escudilla IA*. En imagen pieza procedente de la Catedral de Oviedo.





Producciones esmaltadas y decoradas en azul halladas en Álava  
(Ibabe Ortiz, 1995, p. 68)





Muchas gracias  
*Moltes gràcies*

Miguel Busto Zapico  
Universidad de Granada  
[bustomiguel@ugr.es](mailto:bustomiguel@ugr.es)



**UNIVERSIDAD DE GRANADA**

Departamento de Historia Medieval y Ciencias y Técnicas Historiográficas  
Facultad de Filosofía y Letras